

Fit and Finish Installation Guide

For Siding and Vinyl Carpentry™
Soffit and Decorative Trim



Celebrating a Century of Building America



Important Information

Warranties

These instructions describe and illustrate the steps involved in installing Wolverine siding and trim. Their purpose is to provide detailed information and how-to tips that will simplify the installation process. Wolverine shall not accept any liability or responsibility under its written warranty for failure caused by application that does not meet the requirements for proper installation. These requirements are outlined throughout this book. Any deviations from these requirements should be addressed and approved in writing by Wolverine.

Wolverine is not responsible for moisture protection. Please check your warranty for details.

In rare incidents, intense sunlight reflected from glass on vinyl siding may create heat buildup and cause the siding to distort. To help minimize the effects of heat buildup from reflected sun, the homeowner may take one or more of the following measures:

- Install a screen in the window causing the problem
- Install an awning over the window to break the line of light reflection
- Use shrubbery to protect the area of siding from reflections

Building codes and regulations vary throughout the country. Be sure to check with your local code official or governing body for the building requirements in your area.

Important Fire Safety Information:

Exterior vinyl building materials require little maintenance for many years. Nevertheless, common sense dictates that builders and suppliers of vinyl products store, handle and install vinyl materials in a manner that avoids damage to the product and/or the structure. Owners and installers should take a few simple steps to protect vinyl building materials from fire:

- **To Home and Building Owners:** Rigid vinyl siding is made from organic materials and will melt or burn when exposed to a significant source of flame or heat. Building owners, occupants and outside maintenance personnel should always take normal precautions to keep sources of fire, such as barbecues, and combustible materials, such as dry leaves, mulch and trash, away from vinyl siding.
- **To the Building Trades, Specifiers, Professionals and Do-It Yourself Installers:** When rigid vinyl siding is exposed to significant heat or flame, the vinyl will soften, sag, melt or burn, and may thereby expose material underneath. Care must be exercised when selecting underlayment materials because many underlayment materials are made from organic materials that are combustible. You should ascertain the fire properties of underlayment materials prior to installation. All building materials should be installed in accordance with local, state and federal building codes and fire regulations.

This manual shows the basic guidelines for installation. It is based on ASTM (American Society for Testing and Materials) D4756, the standard practice for installation of vinyl siding and soffit. Additionally, we recommend that local building codes be reviewed.



Become a Wolverine Master Craftsman

The Wolverine Master Craftsman Program is your opportunity to earn valuable rewards while maintaining a leg up on your competition. These rewards are not available to everyone, just to those who have successfully passed the Master Craftsman Education and Development test.

As a Master Craftsman, you are entitled to:

- Receive a personalized Certificate of Completion that you can use to promote your professional services.
- Be listed as a Master Craftsman on our contractor locator website, where potential customers can find you. The listing will include your name, company name, phone number, e-mail address, and a link to your website if you have one.
- Have access to the Master Craftsman website, which includes Building Solutions® program information, industry news and information, and product and installation updates.

For more information about the
Wolverine Master Craftsman program, call

888-838-8100

or log on to

www.siding.com/mastercraftsman

TABLE OF CONTENTS

SECTION 1 – Introduction	5	SECTION 5 – Installing Horizontal Siding	
SECTION 2 – Materials and Tools		Cutting Panels.....	56
Siding Terms.....	6	Overlapping Panels.....	56
Starter Strips	7	Preparing Wall Surfaces	57
J-channels and F-channels	9	STUDfinder™ Installation System.....	60
Utility Trim.....	10	Completion.....	63
Miscellaneous Accessories	11	Shutter Installation	64
Lineal Options	12	SECTION 6 – Installing Vertical Siding	
Cornerposts.....	13	Preparing Wall Surfaces	65
Equipment and Tools	14	Installing Cornerposts.....	66
Transporting and Storing Vinyl Siding.....	15	Installing Top and Bottom J-channel	66
SECTION 3 – Estimating		Installing J-channel at Gable Ends.....	67
Siding.....	17	Install Window and Door Trim	68
Measuring.....	19	Installing Wall Panels	69
Estimating Form.....	20	Installing Gable End Panels.....	70
SECTION 4 – Preparation for Horizontal Siding		SECTION 7 – Porch Ceilings, Soffit, Fascia	
Preparing Wall Surfaces	21	Requirements for Proper Soffit Ventilation.....	71
Nailing, Stapling and Other Fastening Methods	24	Porch Ceilings	72
Expansion and Contraction	26	Soffit.....	73
Installing Accessories	26	InvisiVent™ Soffit	77
Outside Cornerposts.....	28	Fascia	78
Extra Wide Cornerposts.....	30	SECTION 8 – Installing Specific Wolverine Products	
Inside Cornerposts.....	31	Restoration Shapes™ Half-Rounds Installation.....	80
Federal Corners.....	32	Half-Rounds in Gable Ends.....	84
Inside Federal Corners.....	33	Half-Rounds on Non-vertical Walls.....	87
Trimming Bay Window Corners.....	34	Starting Half-Rounds over Horizontal Siding.....	88
Decorative Trim Options around		Starting Half-Rounds with Lineals over Horizontal Siding....	89
Windows and Doors	35	Application of Half-Rounds under Soffit.....	90
Window Flashing.....	36	Replacing a Damaged Half-Rounds Panel	
Installing Window and Door Trim.....	37	with the Repair Kit (Option 1).....	91
Drip Clip™	38	Replacing a Damaged Half-Rounds Panel (Option 2).....	95
Lineals and Decorative Trim.....	38	Random Hand-Split Shakes Installation	96
Snap-on Lineal Application around		Installing Millennium®	99
Windows and Doors	39	Installing TrueComfort™	102
Lineal Starter Application for Windows		SECTION 9 – Special Situations	
and Door Surrounds	41	Trimming Curved Openings.....	104
Lineal Application around Windows	42	Frieze Board	105
Blind Miter.....	45	Decorative Sunbursts	105
Corner Blocks	46	SECTION 10 – Repair	
5" Square Header with Endcaps		Replacing a Damaged Siding Panel	108
over 3-1/2" Lineals Sides and Bottoms.....	47	Replacing a Damaged Outside Corner Post	108
Creating End Caps for 5" Lineals	48	Repairing Buckled Siding at the Joist.....	109
5" Angled Header with Endcaps over		SECTION 11 – Miscellaneous	
3-1/2" Lineals Sides and Bottoms.....	49	Cleaning Vinyl Siding	110
Crown Molding Treatment Options	50	Siding over Asbestos.....	111
Crown Molding and Cap for 3/4" Pocket J-channel....	51	Historic Restoration	111
Crown Molding with 3-1/2" Lineal Surround	51	For More Information	112
Crown Molding with Cap for 5" Header Lineal.....	52		
Installing J-channel as Gable End Trim	54		
Using Lineals as Gable Trim	55		

SECTION 1

Introduction

Plan your work, then work your plan.

That's the key to success with any project, and it's doubly true when it comes to installing vinyl siding, soffit, trim and accessories.

If you use the right materials and the right tools in the right order, you'll complete remodeling and new home installations in less time, with less effort, and with far greater satisfaction.

Since you're using Wolverine products, you've already taken the first step toward success. Wolverine sidings, soffit, trim and accessories provide premium quality, rugged durability and outstanding appearance. Quite simply, they're made to look great—on the day they're installed and for years after.

The second ingredient of success—using the proper tools, techniques and procedures—is covered in this book. As you'll see by scanning the table of contents, this book guides you through every step of the installation process, from estimating materials to attaching mailboxes and shutters. Every major installation project is covered: horizontal and vertical siding, soffit and fascia, porch ceilings and decorative trim. Where various approaches to a particular installation procedure are possible, the book presents practical alternatives. To make the instructions as detailed and complete as possible, dozens of illustrations accompany the text.

As you're reading—and while you're working—keep in mind the most important rule of thumb for successful vinyl siding installation: allow for movement. All vinyl siding, soffit and accessories used in exterior applications must be able to move freely as they expand and contract with temperature changes. You'll see this point emphasized again and again throughout this book; you'll also learn various techniques for measuring, fitting and nailing that will allow this unobstructed movement. These are perhaps the most important lessons in this booklet.

NOTE: No instruction book can anticipate all the questions that might arise during a siding or soffit installation. Recognizing this, we've focused on the tools and techniques used to complete typical installations. Where appropriate, we've also included alternative approaches for specific installation steps. If you encounter a unique installation problem not covered in this book, we suggest you contact your building materials distributor or call our Sales Support Group at 1-888-838-8100.

SECTION 2 - Materials and Tools

Siding Terms

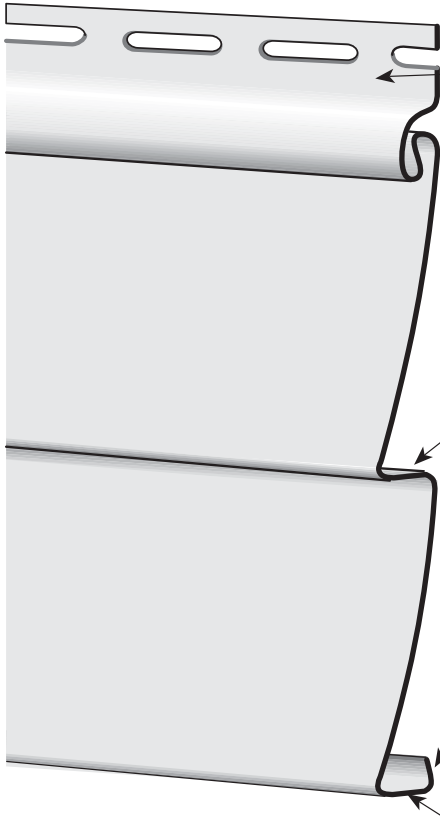

Nail Flange

Common to most vinyl siding products (includes horizontal and vertical sidings, soffits and most accessories).

Lock

Common to most vinyl siding products (includes horizontal and vertical sidings, soffits and some accessories).

Panel Projection

Common to products with multiple faces (i.e. Double 4 or Triple 3). It is the dimension required for the proper selection of receiving channels (e.g., J-channels and corner pieces).

Butt Leg / Locking Leg

Common to most vinyl siding products (includes horizontal and vertical sidings and soffits and some accessories).

Panel Projection

Common to most vinyl siding products that lock into one another (e.g., siding into starters or siding panels into siding panels).

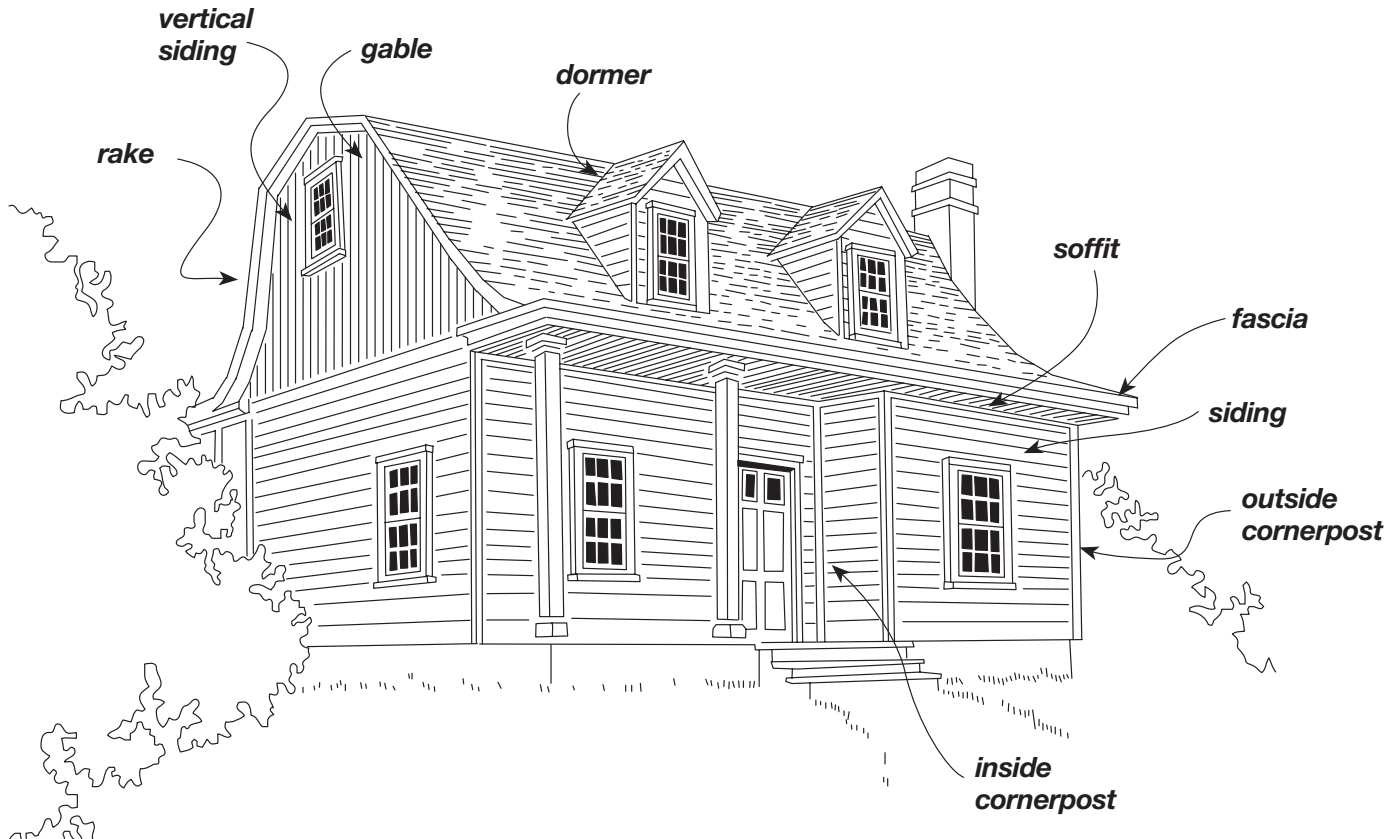

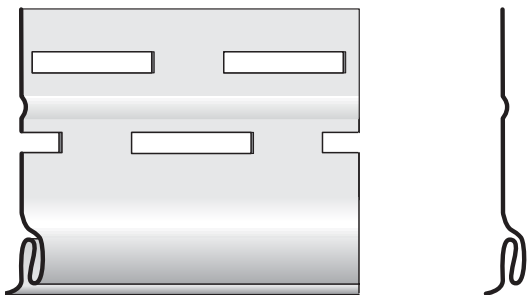

Starter Strips

2-1/4" Vinyl Starter Strip

Secures the first course of siding to the home. For use with all Wolverine sidings except Restoration Shapes Half-Round Shingles and TrueComfort.

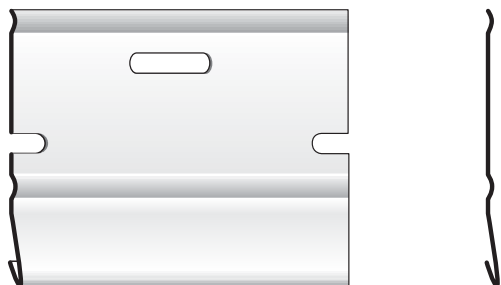

2-1/2" Metal Shingle Starter Strip

For use with all Wolverine sidings except Restoration Shapes Half-Round Shingles and TrueComfort.



5" Metal Starter Strip

Designed to be used on remodeling jobs to help level the first course and span areas that cannot be nailed. For use with all Wolverine sidings except Restoration Shapes Half-Round Shingles and TrueComfort.

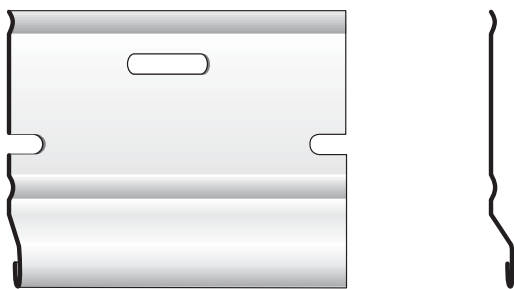

Restoration Shapes Starter Strip

2-1/2" metal starter to be used with Restoration Shapes Half-Round Shingles.

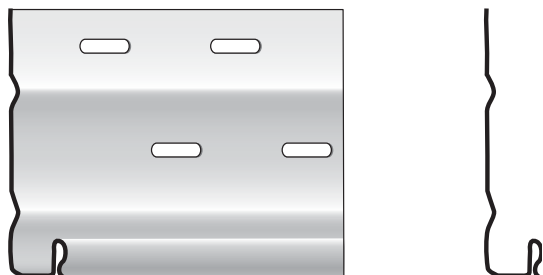

TrueComfort Starter Strip

Vinyl starter strip that accommodates 1-1/4" thickness of insulated siding.

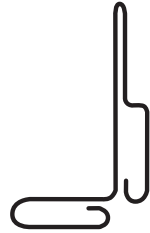
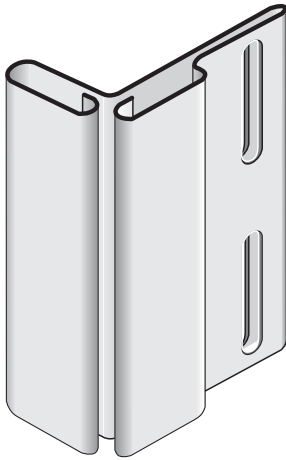

Corner Starter Strip

Secures 3-1/2" and 5" lineals and a corner insert to the outside corner.

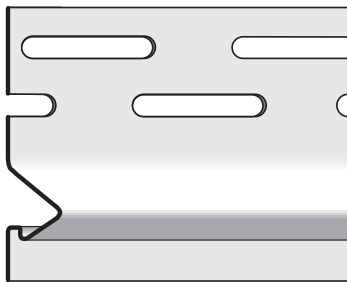

New Construction Window and Door Starter

Butts up against protruding window and door jambs and overhangs for installation of 3-1/2" and 5" lineals.

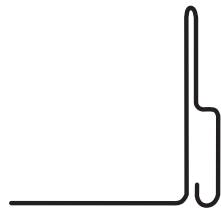
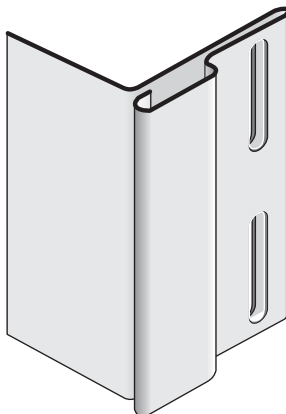

Remodeling Window and Door Starter

Holds 3-1/2" and 5" lineals in place around window and door openings. Used in re-siding applications where existing casings have not been removed.

J-channels and F-channels

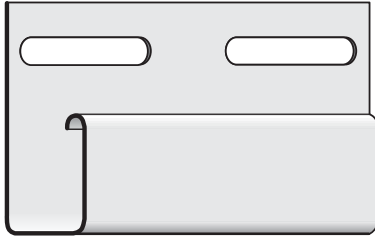

3/8" J-channel

1/2" J-channel

3/4" J-channel

1" J-channel

1-1/4" J-channel

Universal siding and soffit receiving channel for use around utility openings, under eaves, etc.



3/4" Flexible J-channel

Specialized 3/4" siding receiving trim; particularly useful around curved windows and ventilation treatments.

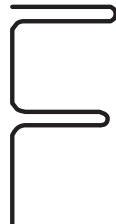
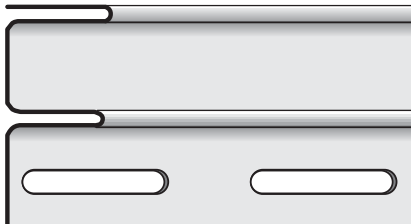

5/8", 3/4", and Deluxe F-channel

Receive soffit panels. Deluxe F-channel can also be used to receive Cornice Molding.

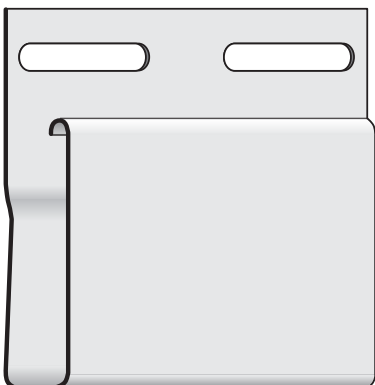

2-1/2" Window and Door Casing

A 2-1/2" wide-face J-channel that accentuates windows and doors. Designed to accommodate new construction window flanges and fit snugly against window and door frames. This accessory is also ideal for gable trim applications.

Utility Trim



Undersill Trim

Helps secure trimmed siding panels under windows and eaves.

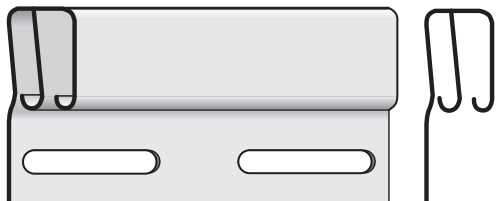

Dual Undersill Trim

Secures trimmed siding panels under windows and eaves regardless of the profile or where in the panel face the panel has been trimmed.

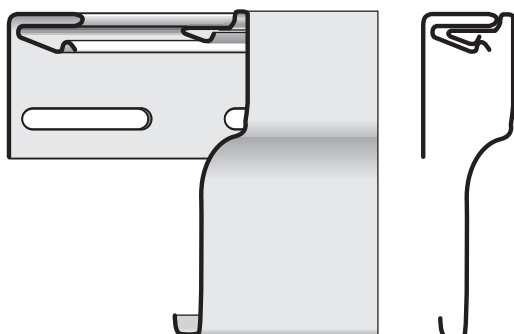

Cornice Molding Receiver

Installed under eaves to hold the Cornice Molding in place. Does not receive soffit panels.

Cornice Molding

Held in place by the F-channel or Cornice Molding Receiver, this accessory hides the installation of the topmost siding panels. With the help of a nail slot punch, topmost siding panels can be installed with nails every time. Can also be used under windows. Great for use with Restoration Shapes.

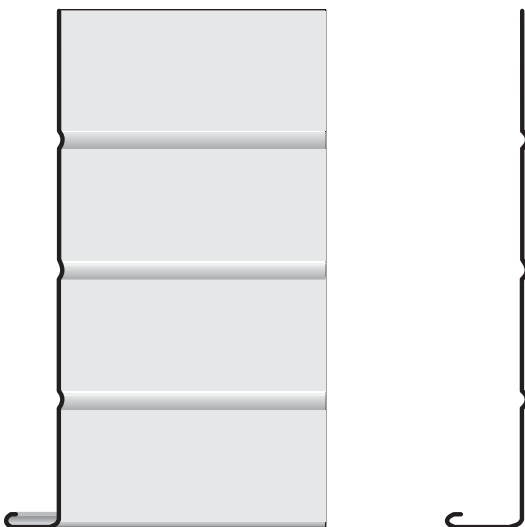

Vinyl Fascia

Installed with F-channel and Undersill Trim to provide a maintenance-free fascia board.

Miscellaneous Accessories

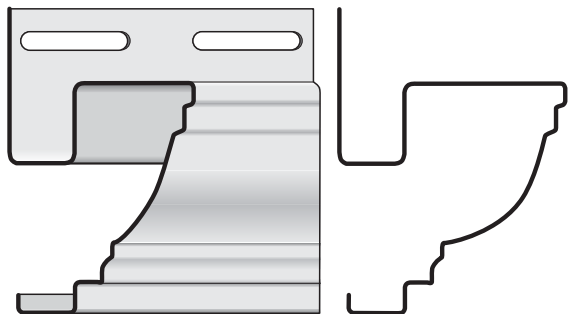

Crown Molding

Used in conjunction with 5" lineals to create a custom molded window or door header. Can also be used with 3-1/2" lineals and 3/4" pocket J-channels. Crown has a 2-1/4" top exposed edge.

Crown Molding Cap

Caps the ends of a crown molding with minimal cutting.

NOTE: *Shown already cut in half – one piece makes a left and right-end cap.*

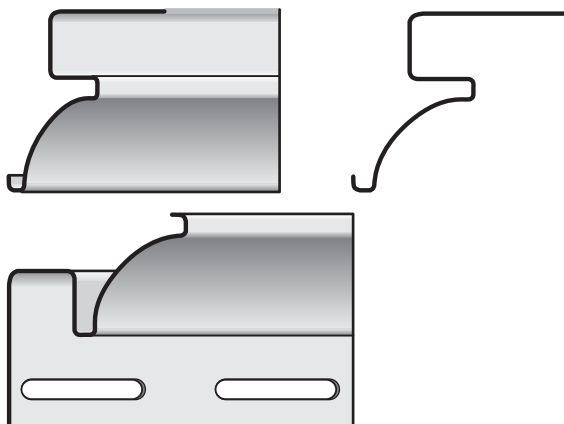

Soffit Cove Trim

(Shown as if secured to trusses or soffit nailers.)

A decorative soffit receiver featuring a 9/16" receiving pocket.

(Shown as if attached to wall substrate. This profile can also be used as an inside cornerpost. Will not work for all profiles.)

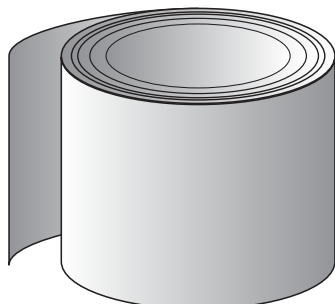

Aluminum Trim Coil

24"-wide PVC-coated aluminum.

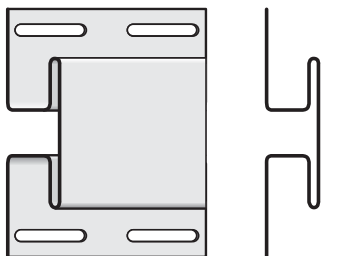

3/8" H-bar
1/2" H-bar

Joins soffit panels. Particularly useful on porch ceilings and hip roof applications.

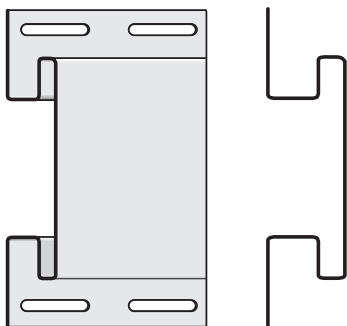

3-1/2" Double Channel Lineal
5" Double Channel Lineal

Exposure matches 3-1/2" window and door surround lineals.

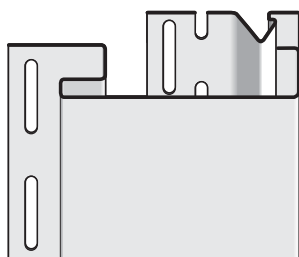

Lineal Options

3-1/2" Lineal

For use with a New Construction Window and Door Starter around windows and doors as a casing. The 3/4" channel receives siding panels. Can also be used as a cornerpost.

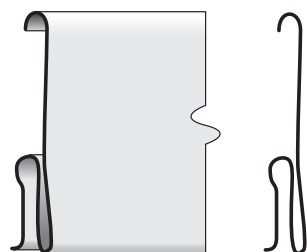

3-1/2" Snap-on Lineal

For use with J-channel.

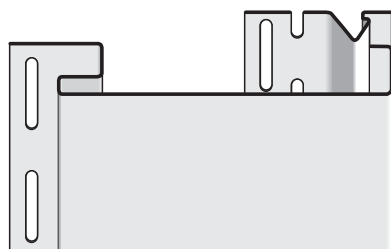

5" Lineal

Two lineals create a corner system when installed with a Corner Starter and corner insert. Can also be used with a window starter strip as a window/door casing. The 3/4" channel receives siding panels.



Quarter Round Insert

Installed with a Corner Starter and lineals as a decorative corner treatment.

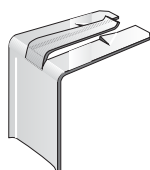

Drip Clip™

Use to create a rain tab on lineals.

Cornerposts

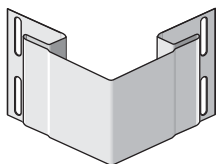

Outside Cornerposts

3/4" Outside Cornerpost – Woodgrain

3/4" Outside Cornerpost – Matte

1" Outside Cornerpost – Woodgrain

(For use with Restoration Shapes Random Hand-Split Shakes)

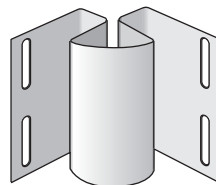

3/4" Inside Cornerpost – Matte

Used where siding meets at inside corners; provides a finished look.

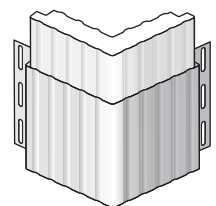

Fluted SuperCorner

Fluted corner design with foam insert.

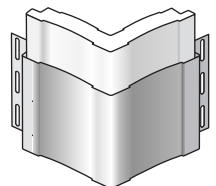

Traditional SuperCorner

Wide decorative traditional corner treatment with foam backing.

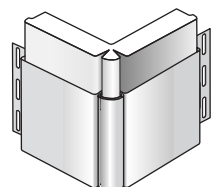

Beaded SuperCorner with Optional Insert

Wide decorative beaded corner treatment with a foam backing and optional beaded insert.

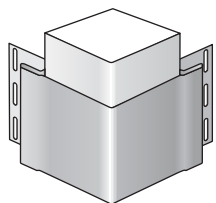

TrueComfort Cornerpost

Corner treatment for use with TrueComfort Insulated Siding.

Equipment and Tools

Sheathings

In new construction, apply sheathing first, then nail accessories over it.

In home improvement projects, you can apply sheathing first, as described above, or you can apply accessories first, then fit sheathing and siding into accessory recesses.

The application method you choose determines the width of the recess opening required. Use:

- 1/2" opening when applying accessories over sheathing and installing siding with a panel projection of 1/2" or less.
- 3/4" opening when applying accessories over sheathing and installing siding with a panel projection of 3/4" or less.
- 1-1/4" opening when applying accessories first and using sheathing that's less than 3/4" thick for sidings with a panel projection of 1/2" or less. For sidings with a panel projection of 5/8" or 3/4", use a sheathing that is 1/2" thick or less.

Fasteners

Use only corrosion-resistant nails (aluminum, stainless or galvanized roofing.) Nails should have a minimum head diameter of 3/8". Staples should be a minimum of 16 gauge.

If screws are used, use non-corrosive, self-tapping, pan head or washer head screws or oval head with countersunk washer screws with at least 3/8" (9.5mm) diameter head, 1/8" (3mm) diameter shaft, and at least 1-1/8" (29mm) long.

To determine the length of nail required, measure the thickness of the sheathing material. Then add at least 3/4" to allow the nail to penetrate the solid wood substrate (studs or existing wood siding). For more secure fastening, add 1" to sheathing thickness. The minimum nail size should be 1-1/2".

Example: If you're applying siding over 3/4" sheathing, use a nail at least 1-1/2" long (3/4" + 3/4").

To determine the quantity of nails required, complete the following:

Total square feet of siding required: _____

(if using aluminum nails)	x	.005
(if using galvanized roofing nails)	x	.01

Pounds of nails required: = _____

For nailing instructions, see page 24.

Tools Required

Hammer	Tin snips	Tape measure
Square	Chalk line	Level
Utility knife	Hacksaw	Shears

Power circular saw with sharp, fine-tooth plywood blade mounted in reverse direction.

Ladders and scaffolds

NOTE: *If you will be using an extension ladder during installation, be sure to cushion the upper side rails to help prevent damage to installed siding.*

Cutting table

Portable brake

Essential for bending aluminum trim coil to fit around fascia boards, window sills, window and door casings, etc. Please refer to the brake manufacturer's instructions for metal bending techniques.

Transporting and Storing Vinyl Siding

If you are transporting vinyl siding to a job site, make certain to keep cartons flat and supported along their entire length.

At the job site, take the following precautions when storing panels:

- Store on a flat surface and support the entire length of the carton.
- Keep cartons dry.
- Store away from areas where falling objects or other construction activity may cause damage.
- Do not store in any location where temperatures may exceed 130° F (e.g., on black top pavement during unusually hot weather or under dark tarps or plastic wraps without air circulation).

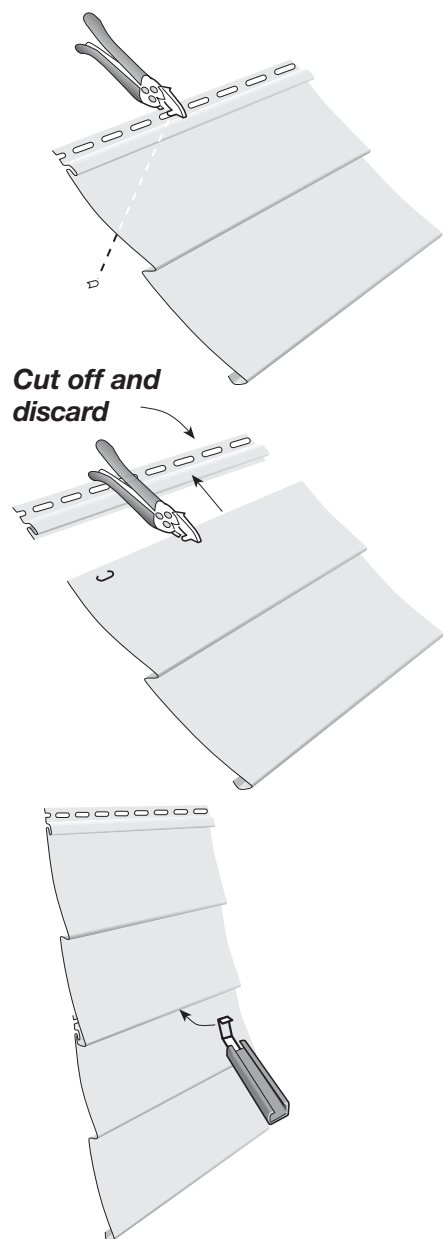

Special Tools

Nail Slot Punch

Punches elongated holes to allow nailing the cut edge of a panel. Also used to enlarge an existing hole to allow proper nailing.

Snap Lock Punch

Punches tabs in the cut edge of a panel used as a finishing course at the top of a wall or underneath a window. The tabs lock into undersill trim. For best results, we recommend using an SL5 punch, which is designed specifically for vinyl applications. You may also use a redesigned and improved version of the SL5 punch. To be certain you're using the right model SL5, make sure it was manufactured after November 1987.

Zip Tool

Locks and unlocks panels.

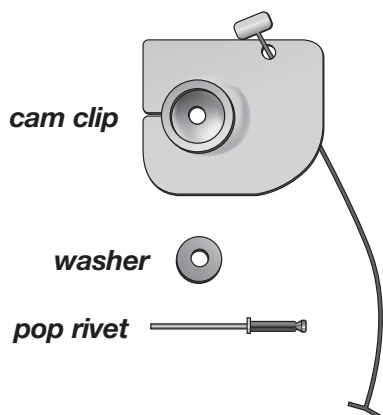

Shingle Repair Kit

Use one kit to repair one Half-Rounds panel.

SECTION 3 – Estimating

Siding

Use the illustrations and formulas below and enter totals on the estimating form in this section. These formulas apply for both horizontal and vertical installations.

NOTE: *When estimating for a large project, you may want to add a waste allowance of 10 percent to the totals for siding, soffit and accessories.*

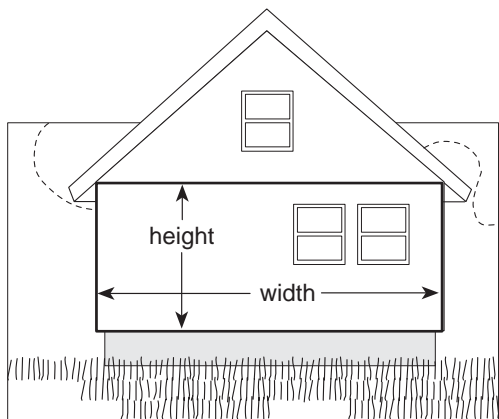

Rectangular wall surfaces

Measure height (excluding gables). Measure width (including doors and windows).

$$\frac{\text{_____}}{\text{(height)}} \times \frac{\text{_____}}{\text{(width)}} = \frac{\text{_____}}{\text{(surface area)}}$$

Repeat for remaining walls.

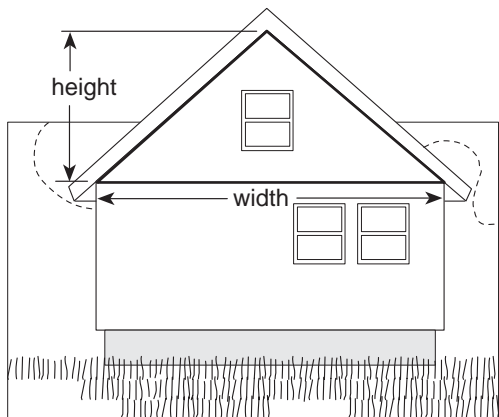

Triangular gable end surfaces

Measure height at center (add 1' to allow for waste). Measure width and divide by half.

$$\frac{\text{_____}}{\text{(height)}} \times \frac{\text{_____}}{\text{(1/2 width)}} = \frac{\text{_____}}{\text{(surface area)}}$$

Repeat for remaining gables.

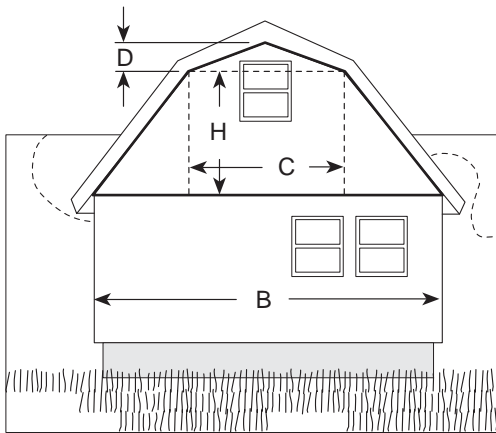

Upper wall of gambrel house

Divide the upper wall of a gambrel house as shown in the illustration. Then use the following formulas:

$1/2 (B + C) \times H =$ _____

$1/2 C \times D =$ _____

Add these figures to get total area: _____

Repeat for remaining gambrel surfaces.

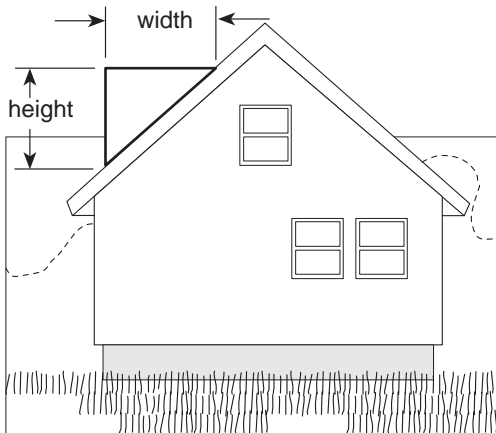

Dormer sides

Measure height of dormer (add 1' to allow for waste). Use the following formula:

$\frac{\text{_____}}{(1/2 \text{ height})} \times \frac{\text{_____}}{(1/2 \text{ width})} = \frac{\text{_____}}{(\text{surface area, 1 side})}$

$\frac{\text{_____}}{(\text{surface area, 1 side})} \times 2 = \frac{\text{_____}}{(\text{total dormer surface area})}$

Repeat for all dormers.

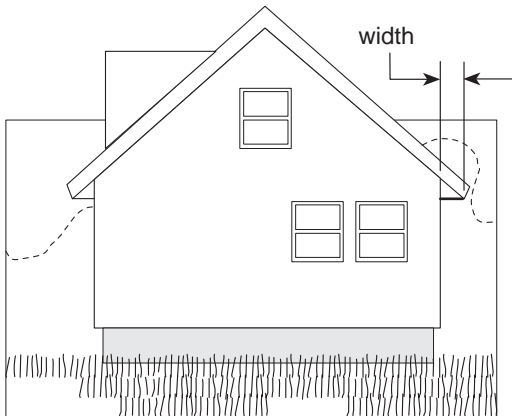

Soffit

Measure width of eave to be covered. Measure length of eave.

$\frac{\text{_____}}{(\text{width})} \times \frac{\text{_____}}{(\text{length})} = \frac{\text{_____}}{(\text{surface area})}$

Repeat for remaining eaves.

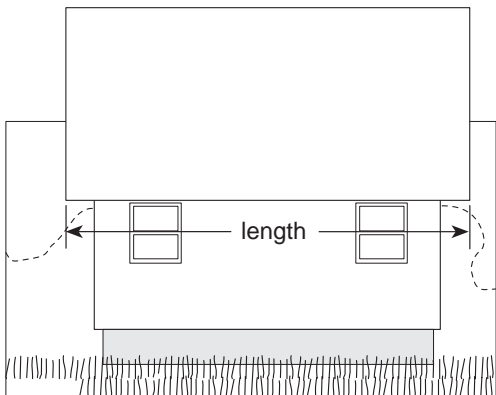

Porch Ceiling

Measure length of porch area to be covered. Measure width of porch.

$\frac{\text{_____}}{(\text{length})} \times \frac{\text{_____}}{(\text{width})} = \frac{\text{_____}}{(\text{surface area})}$

Measuring

Before ordering accessories, you also have to determine the width of the J-channel into which you will fit the vinyl siding. To do this, you must first determine which of two methods you will use to apply sheathings or underlayments. This is covered in more detail under "Sheathings".

Starter strip: Measure along base of building. _____

J-channel: For siding installations, measure around doors and windows, under eaves, at rake edges of gables where dormer meets roofline, and anywhere else required to provide a finished appearance. _____

For soffit, measure along wall under eave and along fascia board. _____

For porch ceilings, measure along perimeter of the porch area. _____

F-channel: For soffit, measure along wall under eave. _____

For porch ceilings, measure along perimeter of the porch area. _____

3-1/2" and 5" lineals: For casing, measure along perimeter of doors and windows. For gables, measure at rake edges of gables where dormer meets roof line. _____

Undersill trim: Measure above and below windows and above doors and top course of siding below soffit. _____

Soffit H-bar: Measure diagonals at all eave corners. _____

Outside cornerpost: Measure length of outside corners. _____

Inside cornerpost: Measure length of inside corners. _____

NOTE: *If you plan to use J-channel instead of inside cornerposts, remember to double this measurement and add the total to your entry for J-channel.*

Dual undersill trim: Measure along top of wall where siding will meet eaves. _____

Estimating Form

Siding	Walls	_____	sq feet	
	Gable ends	_____	sq feet	
	Dormer sides	_____	sq feet	
	Upper gambrel walls	_____	sq feet	
	Total wall surface area	_____	sq feet (A)	
	Large areas not to be covered: (garage doors/sliding glass doors)	_____	sq feet	
		x .50		
	Uncovered area	_____	sq feet (B)	
	Subtract B from A for			
	Total net surface area	_____	sq feet	
Soffit		_____	sq feet	
		_____	sq feet	
Porch Ceiling		_____	sq feet	
		_____	sq feet	
Accessories	Starter strip	_____	lineal feet	
	Window & door lineal starter	_____	lineal feet	
Receiving Channel	Four piece corner starter	_____	lineal feet	
	Utility trim	_____	lineal feet	
	J-channel	_____	lineal feet	
	2-1/2" window & door casing	_____	lineal feet	
	Flexible J-channel	_____	lineal feet	
	F-channel/Deluxe F-channel	_____	lineal feet	
	3-1/2" / 5" lineals	_____	lineal feet	
	New construction window starter	_____	lineal feet	
	Dual undersill trim	_____	lineal feet	
	Outside Corners	Outside cornerpost	_____	lineal feet
		Fluted SuperCorner	_____	lineal feet
		Traditional SuperCorner	_____	lineal feet
		Beaded SuperCorner	_____	lineal feet
Random Hand-Split Shakes/ TrueComfort cornerpost		_____	lineal feet	
Four Piece Corner System		_____	lineal feet	
Inside Corners	Inside Cornerpost	_____	lineal feet	
	J-channel	_____	lineal feet	
Other	Soffit cove trim	_____	lineal feet	
	H-bar: 1/2" or 3/8"	_____	lineal feet	
	Corner blocks	_____	pairs	
	Rosettes	_____	pairs	
	Cornice molding receiver	_____	lineal feet	
	Cornice molding	_____	lineal feet	
	Width of accessory recess opening: (circle one)	_____	1/2" 3/4" 1-1/4"	
	Nails	Pounds required (1-1/2" minimum)	_____	

SECTION 4 – Preparation for Horizontal Siding

Preparing Wall Surfaces

New Construction

Make sure all studs are straight and true. Correct any bowed studs.

NOTE: *Vinyl siding must be applied over a rigid sheathing that provides a smooth, flat surface or an underlayment (such as wood, wood composition, rigid foam or fiber sheathing) that is no more than 1" thick. Vinyl siding cannot be applied directly to studs.*

Make sure sheathing is fastened securely to studs.

If you're planning to use a conventional house wrap or building felt, apply according to the manufacturer's recommendations. In all cases, however, install the products so they are secured firmly to the substrate so that they provide a smooth, even surface for the final siding installation.

Before applying siding, make certain substrate is **watertight**. In order to be properly protected from precipitation, the substrate may need to be properly flashed around areas such as windows, doors, other openings and corners so as to shed water to the exterior. **The siding alone is not meant to be a watertight barrier.**

Drop-In Foam Backer Boards

Some drop-in foam backers can restrict the movement of vinyl siding. Therefore, Wolverine vinyl siding may not be applied over any drop-in foam backer other than a contoured drop-in foam backer designed specifically for each profile.

IMPORTANT: Wolverine will not accept any responsibility or liability in the event the drop-in foam backer restricts the movement of the vinyl. The use, fit, and performance of the siding backer board is the responsibility of the installer and the backer board manufacturer.

NOTE: *Contoured drop-in foam backer boards are not a substitute for rigid foam sheathing.*

Home Improvement Projects

You can prepare your current siding surface to receive vinyl siding in one of three ways:

Strip off old siding and level the wall. If felt paper covers the wall, you have two alternatives: either strip it off completely or staple or nail it to create a smooth surface. If there is no solid sheathing under the old siding, you must apply it as described in the instructions for New Construction, above.

Apply rigid sheathing to existing siding to provide a smooth surface. Nail securely to old siding. Nail evenly to bridge low spots.

NOTE: Failure to establish a smooth, solid surface constitutes misapplication under the terms of the warranty.

Apply vertical furring to old siding to straighten noticeable surface unevenness. (See “Tips for applying wood furring”.) Then apply rigid sheathing, following the instructions presented under New Construction.

NOTE: For information on installing siding over asbestos and for historic applications, see page 111.

Tips for applying wood furring

If you are working on an older home with noticeably uneven walls, you must correct this condition before proceeding. If not corrected during preparation, this uneven surface will produce a wavy appearance in siding applied over it.

For best results, space strips 12" on center. Do not exceed 16". To correct an uneven wall, use furring strips (and wood shims if necessary) to eliminate low spots.

NOTE: You must apply rigid sheathing over furring.

When covering over masonry or bricks, it's better to use 1"x 3" furring. For best thermal performance, install a minimum of 1/4" foam over furring strips.

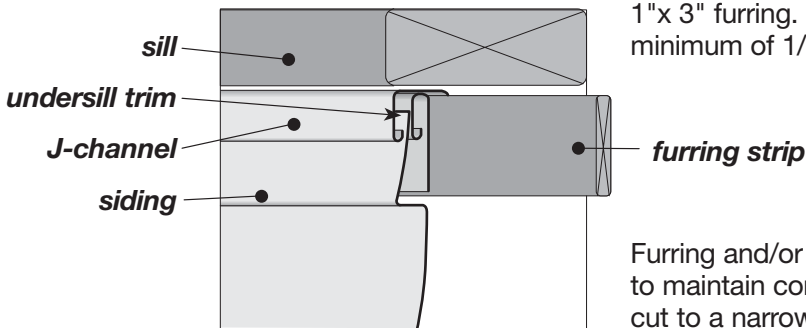

Furring and/or foam is also used below eaves and windowsills to maintain correct slope angles when siding panels must be cut to a narrower dimension to fit.

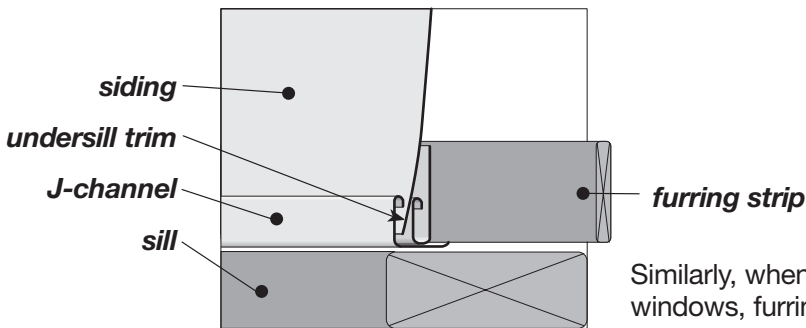

Similarly, when panels are cut to fit over doors or windows, furring and/or foam is used to establish the correct slope angle.

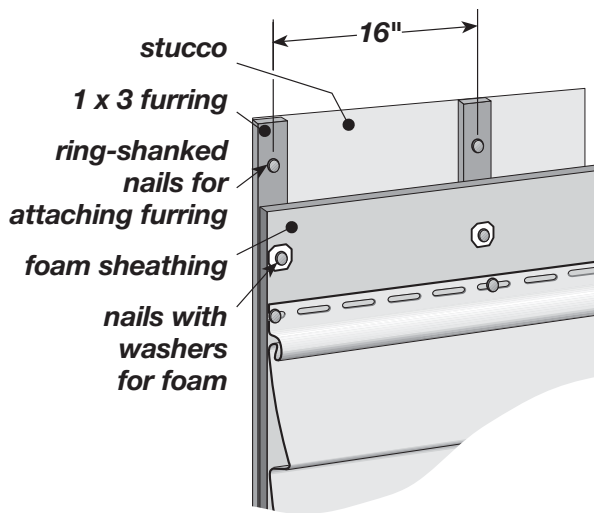

Applying over stucco

When applying vinyl siding over stucco, you first have to be sure you're working on an even surface. To create that surface, you may have to knock down high spots where furring strips will be applied. Use caution when chipping off these spots – you don't want to crack or damage the remaining stucco.

Apply 1" x 3" furring to the stucco, using ring-shanked nails or screws. Stucco will not hold fasteners tightly, so be sure nails or screws are anchored securely to studs. Furring strips should be spaced 16" on center.

Applying rigid foam sheathing to furring

Install sheathing according to manufacturer's instructions. Do not apply siding directly to furring strips. For best thermal performance, install a minimum of 1/4" foam over furring strips.

typical of a pan head, "wafer," "s" truss head or washer head screw

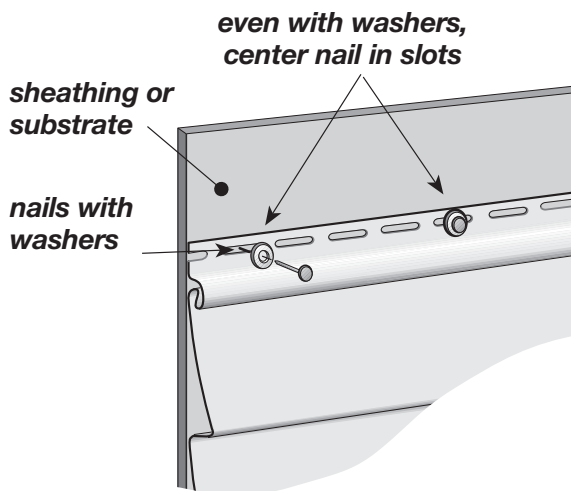
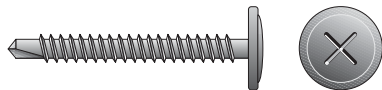

Applying over steel studs

Pre-planning is the key when installing vinyl siding and accessories over steel studs. Pre-planning includes the selection of siding style and the types of accessories. Pre-planning proper stud placement will eliminate many of the problems that could surface once the job has been started, such as at corners, windows, and transitional areas.

Follow the same guidelines as in a wood surface – except for the type of fasteners used. Wall sheathing must be installed over the studs. This will provide a straighter, smoother and more rigid wall surface and help prevent studs from twisting. Siding must be secured into metal studs if the substrate is not a nailable surface such as exterior dry wall, gypsum board, etc.

The application of vinyl siding, soffits and accessories over steel stud framing rather than typical wood framing is straightforward. The main difference is the use of screws to hang components that make up a completed siding job.

Use noncorrosive, self-tapping screws with at least 3/8" (9.5 mm) diameter head, 1/8" (3 mm) diameter shaft, and at least 1-1/8" (29 mm) long.

Although the fastening method for steel studs differs from wood construction, all other procedures still apply, including fastening in the center of the nail slot and not overtightening the fasteners.

Application for high wind areas

Using a 5/8" nylon washer with a 1/4" hole between the nail and siding increases the wind load capabilities of the installation. (Washer tested was 0.071" thick.)

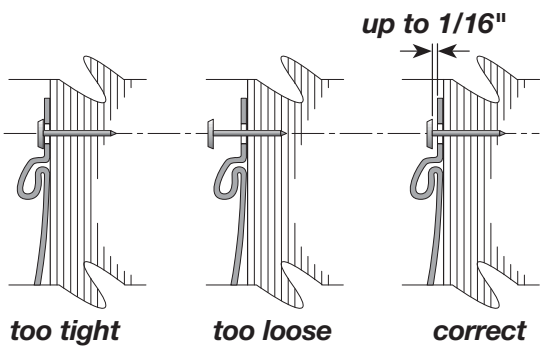
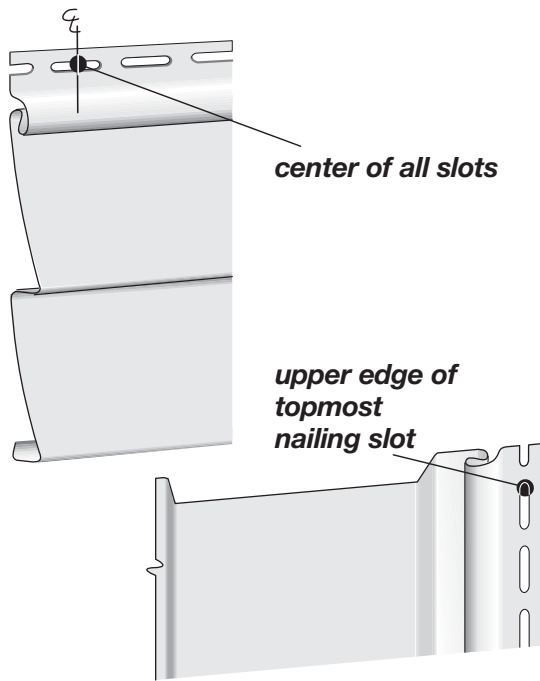

Nailing, Stapling and Other Fastening Methods

If you want to ensure a quality vinyl siding installation, focus your attention on nailing techniques. Unfortunately, a lot of installers don't. They feel nailing is a routine task, something everyone knows how to do. But that's not the case. At Wolverine, we analyzed reported installation problems, and we found that more than half of them can be traced back to improper nailing. So if you want to save yourself lost time and frustration, carefully observe the following guidelines when installing accessories, siding panels, soffit, or porch ceilings.

Lock the panel and begin nailing at the center of the panel, working toward the ends. This helps maintain a level line.

With horizontal accessories and panels, position the nails in the center of the elongated nailing slots to allow for expansion and contraction. Never nail through the panel surface.

With vertical accessories and panels, position the **first nail** at the **upper edge of the topmost nailing slot**. This allows a panel to hang from the nail. Position the remaining nails in the center of the nailing slots. Allow for 1/3 of the total expansion at the top and 2/3 of the total expansion at the bottom.

NOTE: Do not nail too tightly. To permit expansion and contraction, panels should hang freely from nails. This allows the panels to move as the temperature changes. Drive the nails until there is between 1/8" to 1/16" of space between the nail head and the nailing flange.

Drive the nails straight in. Do not angle nails.

Per the ASTM specification for vinyl siding installation (D4756), proper nail penetration is at least 3/4". In most cases, that requires anchoring to studs.

Nails must be spaced a maximum of 16" apart. (In new construction, nail to studs on 16" centers. Do not skip studs.) Elongate factory nail slots if necessary to hit a stud. **Check with your local building code official for special requirements.**

Other fastening techniques:

Manual nailing is the most common way of fastening vinyl siding to a wall. That's because it offers greater control, making it easier to learn how to fasten panels securely, but not tightly. You also can use power screwdrivers or pneumatic staplers/nailers to attach vinyl siding to a wall, but you must take the time to develop the proper skills. If you choose to use one of these alternate techniques, follow all the recommendations above for nail positioning and spacing and the recommendations for substrate preparation on page 57 for horizontal applications and page 65 for vertical. In addition, be sure to observe the following guidelines:

Power screwdrivers

Use noncorrosive, self-tapping truss head screws. Screws must have at least 5/16" diameter head and 1/8" diameter shaft. Screws must be at least 1-1/8" long. If underlayment is less than 3/4" thick and is not considered a nailable surface (for example, foam or exterior grade gypsum), be sure screws are long enough to penetrate at least 3/4" into wood studs or substrate, 1/8" through a steel stud. Be sure screws are centered in the nail slot. Leave 1/16"-1/8" space between the screw head and the panel nailing flange.

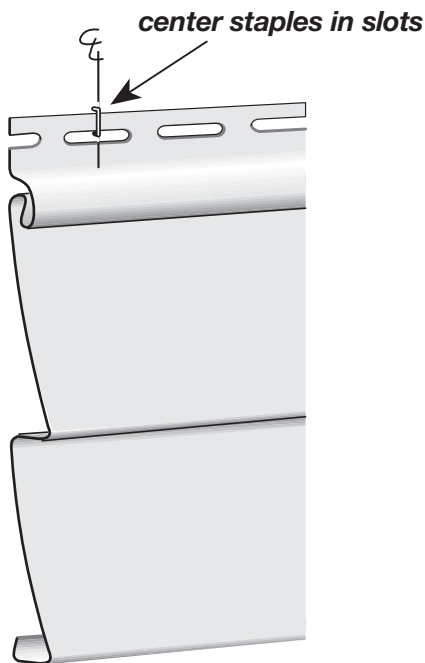

Pneumatic staplers/nailers

Use corrosion-resistant fasteners only. Fasteners must be centered in the nail slot, no more than 16" on center.

NOTE: Some power staplers/nailers use an attachment that helps position the fastener in the nail slot. If your unit does not have that feature, you must carefully position the fastener by sight.

Fasteners must penetrate a nailable surface at least 3/4". Be sure to leave up to 1/16" between the fastener and the panel nailing flange. If you're using a power stapler, drive the staple perpendicular to the nailing slot with one leg of the staple centered in the slot and the other leg above the panel.

1/4" to 3/8"

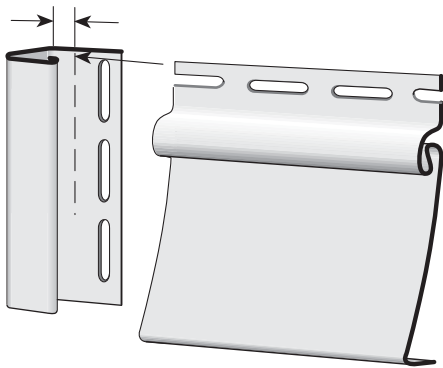

1/3 total expansion

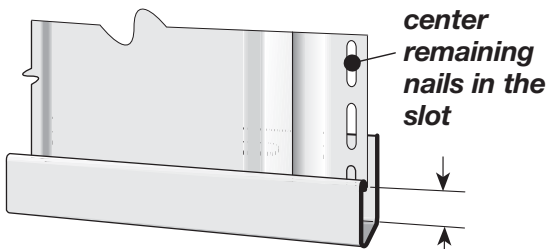
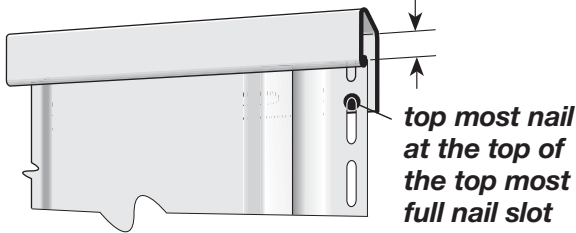

2/3 total expansion

Expansion and Contraction

It's normal for vinyl building products to expand and contract with temperature changes. To ensure a successful siding installation, you must allow for this movement during application.

Use the following guidelines to determine the space required for expansion and contraction between siding and trim:

1/4" at both ends of the panel when the temperature is above 40° F at the time of application.

3/8" at both ends of the panel when the temperature is 40° F or below at the time of application.

In a horizontal siding installation, a vinyl panel tends to expand equally in both directions.

In a vertical siding installation, on the other hand, most of the expansion is downward. So instead of allowing equal space for expansion at both ends of a vertical panel, leave more space at the lower end: 1/3 of the total expansion is allowed at the top of a panel, and 2/3 of the total expansion is allowed at the bottom.

For example, if the temperature is below 40° F, total expansion equals 3/4" (3/8" + 3/8"), so you allow 1/4" at top and 1/2" at the bottom of a vertical panel.

Installing Accessories

Snapping a chalk line

To ensure proper installation, you must establish a straight reference line to guide the positioning of the starter strip and the first course of siding.

If the house is reasonably level, find the lowest point of the old siding (or sheathing if working on new construction). Partially drive a nail at one corner, starter height minus 1/4" above the lowest corner. Attach chalk line. Go to other corner and pull the chalk line taut. Stretch the chalk line from this nail to the opposite corner of the house. Make sure the line is level, using a line level or 4' (minimum) level. Snap chalk line and repeat the procedure around the entire house.

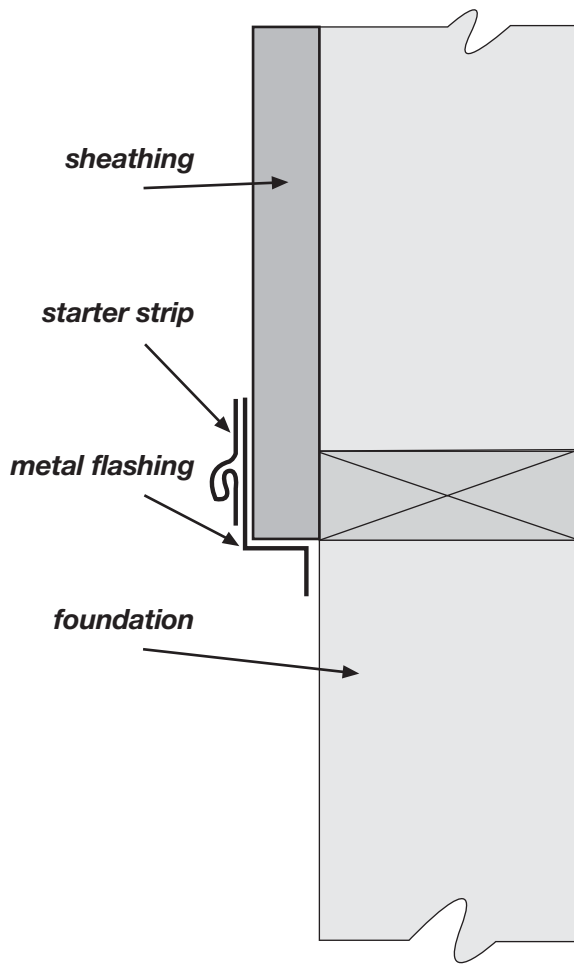

A water level, a long clear plastic tube 90% filled with water, is useful in marking level points around the house and on opposite sides of openings such as doors. Water will always seek a level state, ensuring the markings will always be at the same level.

NOTE: *If after establishing a chalk line you find that your starter strip will be positioned below an easily nailed surface, you may have to apply a nailable base.*

If you have added sheathing, you may want to bend trim coil to act as flashing and help prevent entry of insects. Bend the coil in a "Z" shape so the top edge of the coil is on the chalk line and the bottom edge extends down over the foundation. (See illustration.)

NOTE: *The general guidelines for cutting and nailing vinyl panels and for allowing for expansion and contraction also apply to vinyl accessory items.*

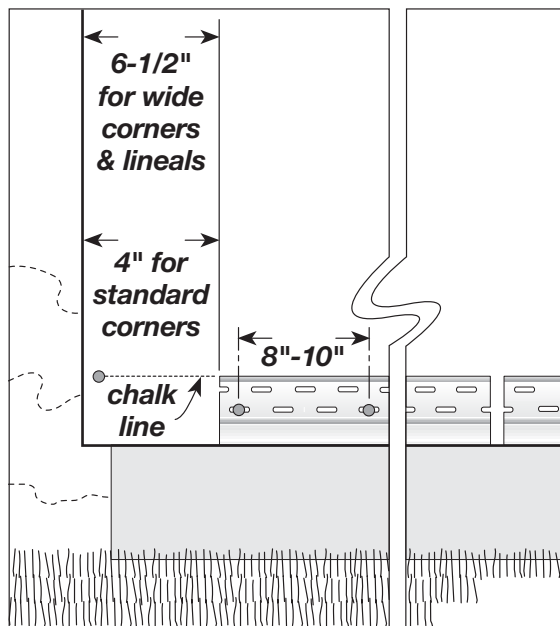

Installing the starter strip

Position the starter strip with the top edge on the chalk line and the ends 6-1/2" away from the outside and inside corners (when using lineal systems or wide corners), 4" if using standard one-piece corners. Nail to wall following previously mentioned nailing instructions. When hollows occur in the wall surface, shim out the starter strip to avoid a wavy appearance in the finished siding job. Nail every 8" to 10".

As you add starter strip sections, be sure to leave 1/4" space between them for expansion.

Sometimes – especially at sills above garage doors, porches or brick surfaces where the siding has been cut lengthwise – you may find it easier to use a combination of utility trim and J-channel as a starter strip to secure a panel (see illustration on page 22).

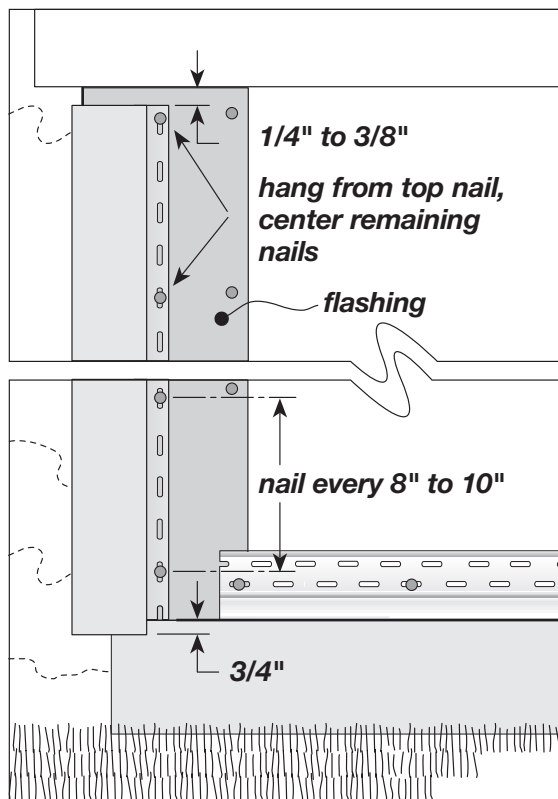

Installing Outside Cornerposts

Flash the corners of the home by bending a 10" wide piece of aluminum trim coil 90° so you have two 5" legs. Cover the entire length of the corner, lapping the upper pieces over the lower pieces.

NOTE: Traditional, fluted and beaded SuperCorners or four piece corner systems require wider strips of coil for flashing.

Position outside cornerpost with the top of the post 1/4" from the underside of the eave and the bottom of the cornerpost 3/4" below the starter strip. Remove the bottom 3/4" of the nailing flange so it will not show below the siding when installed.

Make sure posts are straight and true before nailing.

Hang cornerposts by first positioning a nail at the top of the topmost nail slot. Position all remaining nails in the center of nail slots a maximum of every 8" to 10". Leave 1/8" to 1/16" between the nail head and the cornerpost to allow the cornerpost to move during normal expansion and contraction. This nailing pattern is to be followed on both nail flanges of each post.

NOTE: All SuperCorners and TrueComfort corners install similar to standard outside cornerposts.

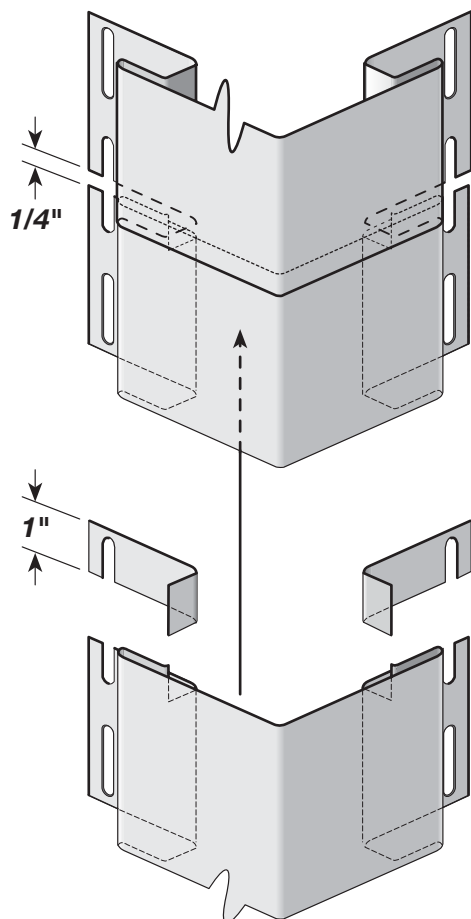

If posts must be spliced for high walls, you have two options:

Option 1: Cut 1" off the nailing flanges and back from the bottom portion of the upper post. Then lap 3/4" of the upper post over the lower post, allowing 1/4" gap for expansion. This method will provide an obvious joint between the two posts, but will allow water to flow over the joint, reducing the chance of water infiltration.

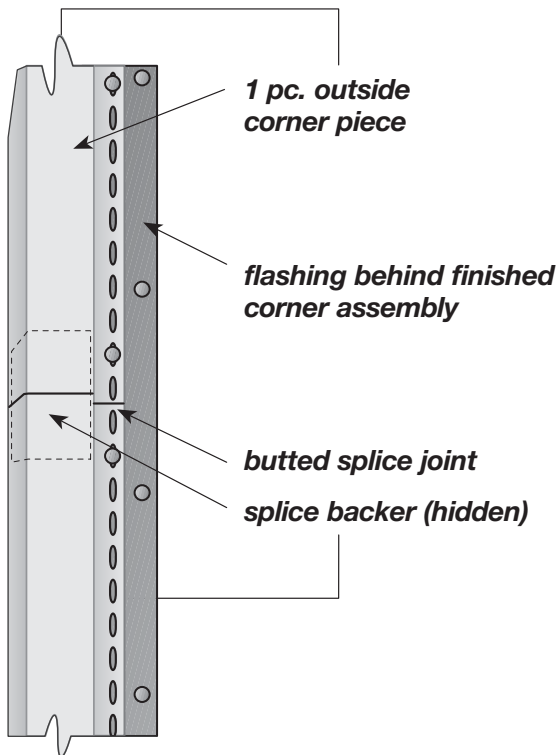

Option 2: Cut a 6" length of cornerpost and trim the nail flange, receiving channel, and sides until you have just a 90° bend of vinyl. Using PVC primer and PVC cement, glue the bent piece to the inside of the upper post and lower post. Butt the two posts together. Nail the entire assembly as one post with all nails in the lower post centered in the nail slots.

Also see additional instructions covering installation of four-piece cornerposts (page 30).

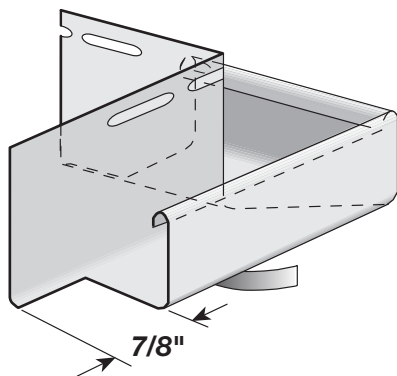
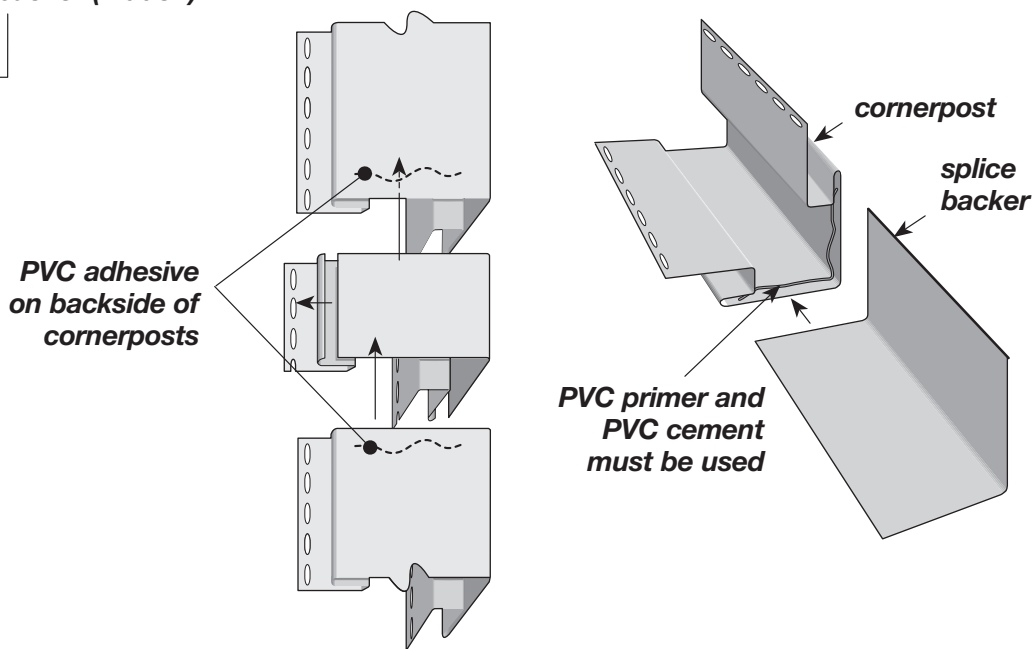

Capping an outside cornerpost

One method of capping an outside cornerpost is to cut a piece of J-channel twice as long as the width of the cornerpost face. Mark a 90° angle from the center and cut out this area. Then cut 7/8" away from each end, except for the nailing flange. Bend the J-channel in the center and nail it to the outside of the corner of the house. Then insert the cornerpost into the J-channel.

Another alternative is to trim the nail flange, receiving channel, and sides from the bottom 1" of the cornerpost. Notch 1" at the 90° bend, fold the bottom 1" of the cornerpost face, and fasten these "flaps" with a pop rivet.

Extra Wide Corner Posts (Four-Piece Corner System)

Extra-wide cornerposts give you a distinctive, easy-to-install method of finishing outside corners. Each cornerpost consists of four parts: Corner starter, two lineals and a 1/4 round snap-in molding.

Lineals are available in two board styles: 5" smooth and 3-1/2" smooth.

The installation procedure is identical for all lineals and inserts. To install this four-part accessory, follow these steps:

NOTE: Make sure the corners are properly flashed.

Cut cornerpost pieces. Measure the vertical span, and allow 1/4" clearance from the underside of the eave and 3/4" below the starter strip. Cut all four pieces using a power circular saw.

Hang a starter strip. Position the starter strip, leaving 1/4" allowance for expansion at top and 3/8" at bottom. Position the first nail at the uppermost edge of top nail slot (shown). Nail loosely. Working from top down, position remaining nails every 8"-10", with nails centered in slots.

Attach side lineals. Lock the first lineal into the starter strip. Nail to the sheathing following the procedure described above. Repeat the process for the other lineal.

Snap in the quarter-round corner insert. Working from the bottom up, begin by inserting the longer leg of the insert into the nail flange side of the starter strip first, then snap in the shorter leg. Lightly press along the length of the molding as you snap it into place.

NOTE: For a more secure installation, use a pop rivet to attach the molding insert to a side lineal. The rivet should be positioned at the top of the cornerpost.

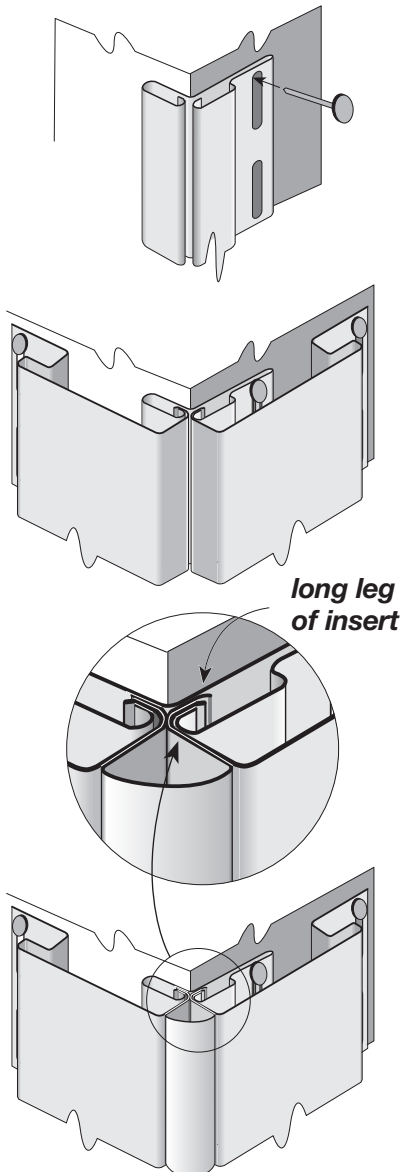

Inside Cornerposts

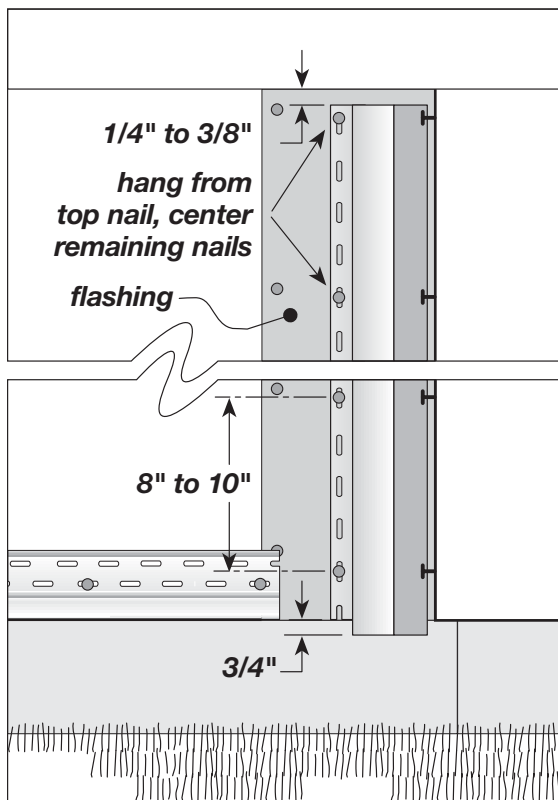

There are three options for trimming inside corners: Standard 3/4" inside cornerpost, single J-channel, and two J-channels.

To flash the inside corner, bend a 12"-wide piece of aluminum coil stock 90° so you have two 6" legs. Insert the flashing into the corner. If you use more than one piece of flashing, overlap the upper pieces of the flashing over the lower pieces.

To install inside cornerpost, hang the post from the top of the eave. The bottom should extend 3/4" below the starter strip. Remove the bottom 3/4" of the nailing flange so it does not show below the siding. Set the post straight and true. Position the top nail in the top of the nailing slot. All other nails should be in the center of the nail slots.

If you have to splice the inside cornerpost, cut 1" off all but the outer face of the lower post. Lap 3/4" of the upper post over the lower post, leaving 1/4" for expansion.

If you are using two pieces of J-channel instead of inside cornerpost, flash the corner with a 6" x 6" "L" corner fabricated from aluminum coil stock. Hang the J-channel from the top of the eave. The bottom should extend 3/4" below the starter strip. Remove the bottom 3/4" of the nailing flange so that it will not show below the siding. Use the same positioning and nailing guidelines as inside cornerpost.

To create a narrower corner, you can also use a single length of J-channel and flashing. First, install the siding on one wall, then place the J-channel lightly against the siding and nail it to the substrate on the adjacent wall. Follow the same positioning and nailing guidelines as inside cornerposts.

NOTE: When using a single J-channel, the corner must have corner flashing

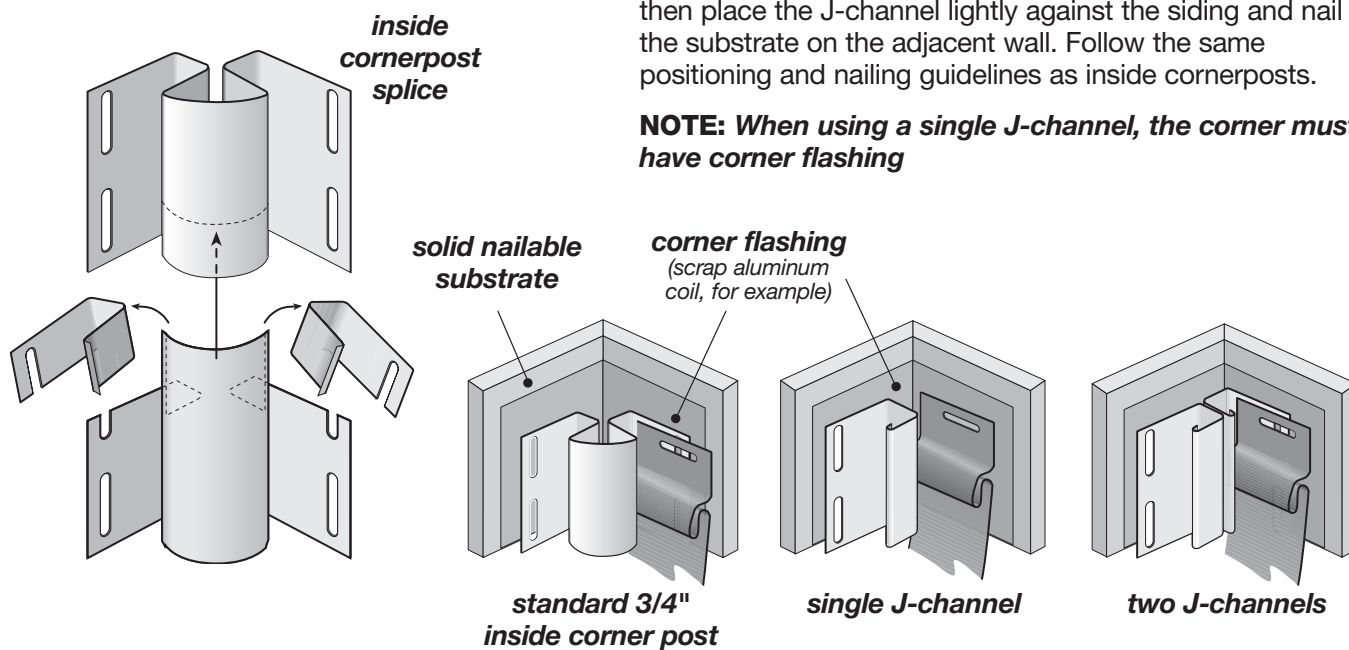

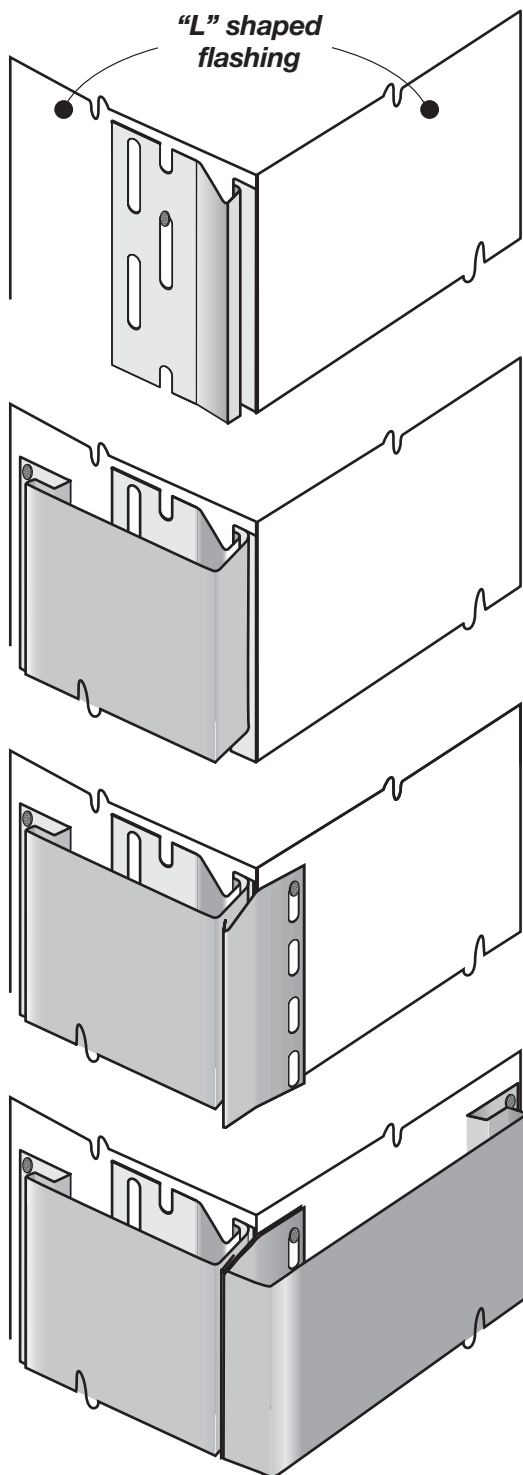

Federal Corners

To create a federal-style corner, flash the corner with aluminum trim coil or other flashing materials. Hang a new construction starter strip. Position the top nail in the top of the nailing slot. All other nails should be centered in the slots spaced 8" to 10" apart.

Position and secure the 3-1/2" lineal.

Position and secure an aluminum starter strip.

Position and secure the 5" lineal.

NOTE: Aluminum starter can be used for both lineals. If the aluminum starter used for the 5" lineal is not long enough, fashion a starter using a metal brake and coil stock to a length that allows for proper nailing into the substrate.

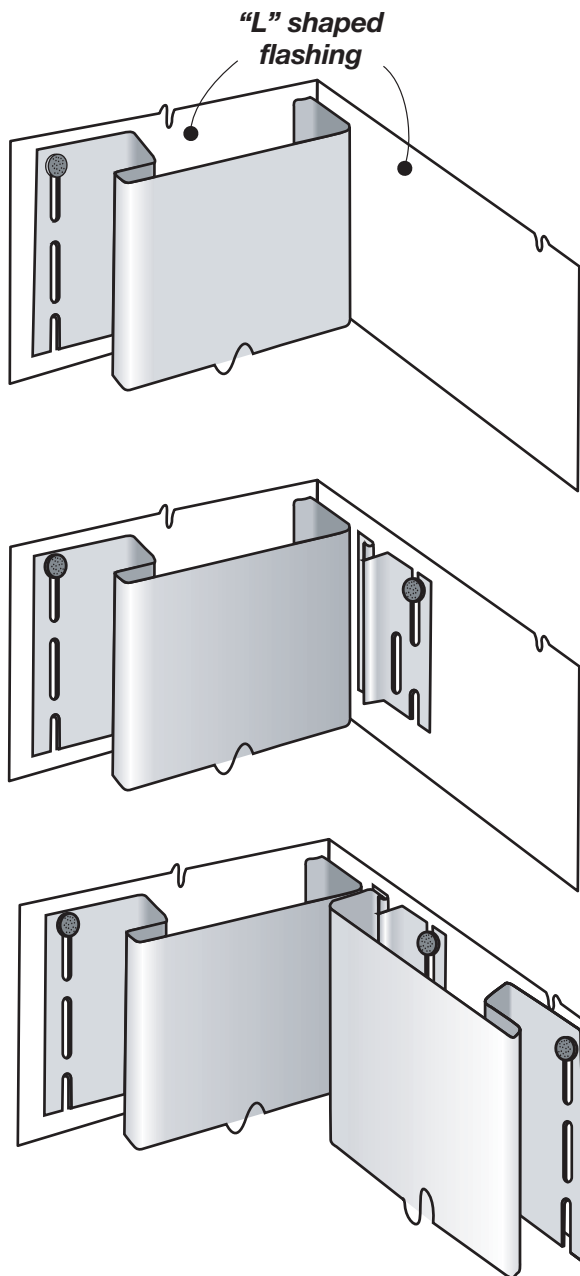

Inside Federal Corners

Flash the corner with aluminum trim coil or other flashing materials.

Position and secure the 5" lineals (or a 3-1/2" lineal) by butting the lineal up to the inside corner. Using a 5" lineal will create a symmetric 3-1/2" exposure in the corner. If two 3-1/2" lineals are used, one exposure will be approximately 2-1/4" and one will be 3-1/2".

NOTE: *Attaching the second lineal will keep the first lineal in place. You will not need a starter strip. Always position the top nail in the top of the nailing slot. All other nails should be centered in the slots spaced 8" to 10" apart.*

Position and secure the starter strip.

Position and secure the remaining lineal.

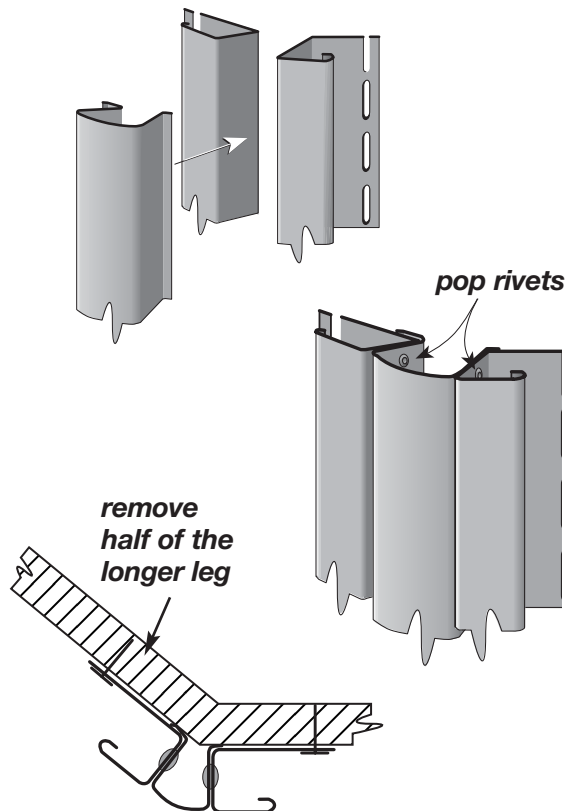
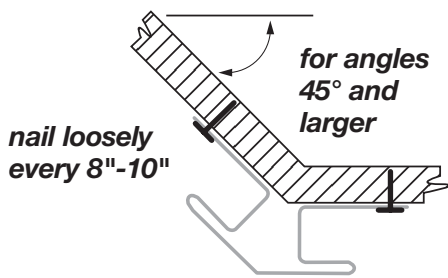
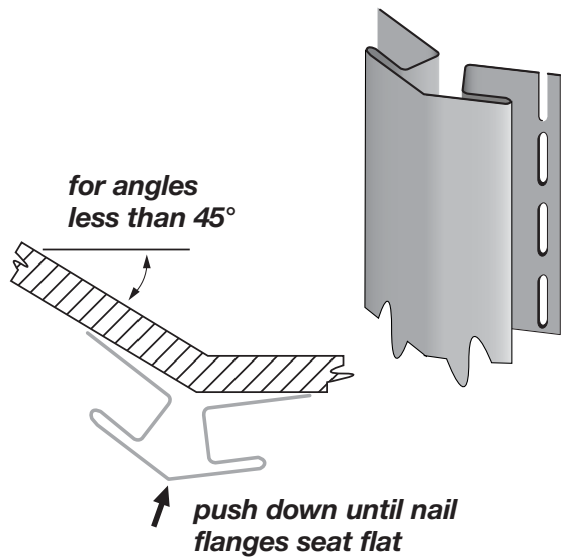

Trimming Bay Window Corners

There are several ways to trim the odd angles of bay windows. Here are two of them:

1. Install bay window cornerpost.
2. Install J-channel with a quarter-round insert.

Before you begin, make sure the corner is properly flashed.

Install Bay Window Cornerpost

- Cut bay window cornerpost to the proper length.
- For angles less than 45°, push down on the face of the corner until the nail flanges seat flat against the wall surfaces.
- Hang the cornerpost by nailing loosely into the topmost nail slot.
- Make sure the cornerpost is straight and true.
- Position all remaining nails in the center of nail slots a maximum of every 8" to 10". Leave 1/8" to 1/16" between the nail head and the cornerpost to allow the cornerpost to move during normal expansion and contraction.
- Fit the siding into the cornerpost. Leave 1/4" for expansion.

Install J-channel with Quarter-Round Insert

- Cut two pieces of J-channel and one piece of quarter-round insert to length.
- Pop rivet the J-channels to each side of the quarter-round insert in at least three places.
- Nail the assembly to the corner, remembering to hang the assembly from the topmost full nail slot.
- Position all remaining nails in the center of nail slots a maximum of every 8" to 10". Leave 1/8" to 1/16" between the nail head and the J-channel for normal expansion and contraction.
- Fit the siding into the J-channels. Leave 1/4" for expansion.

Decorative Trim Options around Windows and Doors

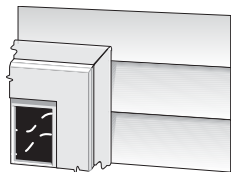

J-channel

System requires standard J-channel.

- 1/2" J-channel
- 3/4" J-channel
- 1" J-channel
- 1-1/4" J-channel



3-1/2" Snap-On Lineal

System requires 1" face J-channel

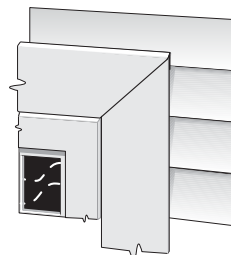

3-1/2" Lineal System

System requires 3-1/2" lineals and starter strips.

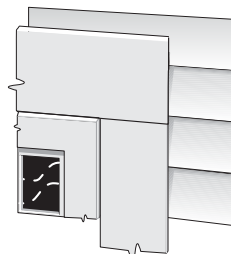

5" x 3-1/2" Lineal System

System requires 5" lineals, 3-1/2" lineals, and starter strips.

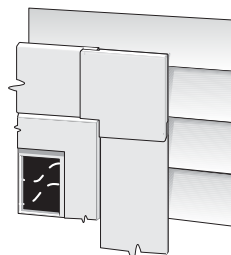

3-1/2" Lineal System with Corner Block

System requires 3-1/2" lineals, starter strips, and lineal corner block.

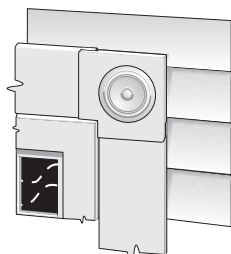

3-1/2" Lineal System with Corner Block and Rosette

System requires 3-1/2" lineals, starter strips, lineal corner block, and rosette.

Window Flashing

The width of all flashings is determined by the type of accessory surrounding the window and where the final complete course of siding stops below the window (in the case of the flashing under the window). The flashing should extend past the nail flanges of the accessory. The width of the flashing under the window must allow for the diversion of water.

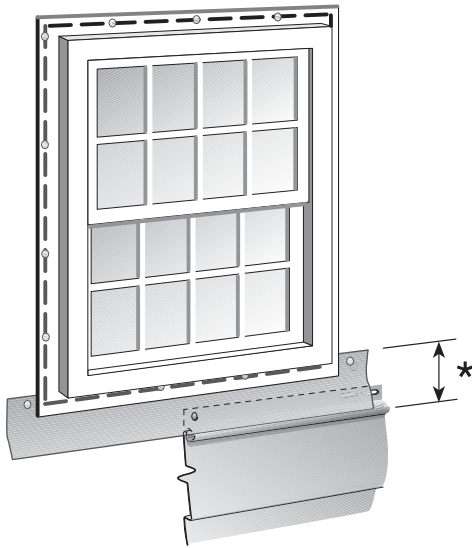

*see NOTE below

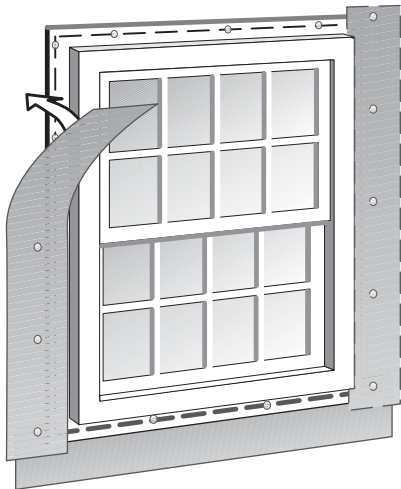

Apply the vertical flashings by overlapping the previously secured bottom flashing. As noted above, the length and width of the flashings will be determined by the type of accessories used.

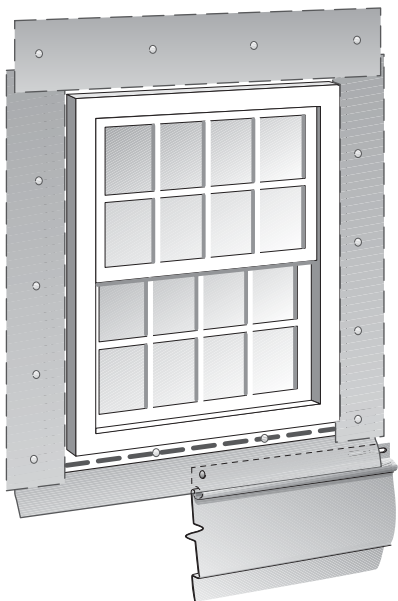

Secure top flashing.

NOTE: *The flashing is long enough to direct water over the nail flange of the last course of complete siding panels.*

For even greater protection, make a slit in the building wrap and insert the top flashing behind it. Tape the seam as shown.

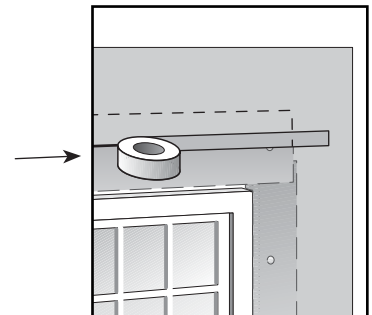

Installing Window and Door Trim

Install J-channel along the top and sides of door casings and around windows.

NOTE: When installing J-channel around replacement windows that do not have nail flanges, add flashing for greater protection against water infiltration. For an example of completed flashing, see the previous page.

There are two methods of joining J-channels at corners. The easiest method is to square cut the corners. For a more finished appearance, you can miter the corners. To prevent gaps, do not butt ends. Instead, lap them as shown.

To Square Cut Corners

Install J-channels at sides of windows. Notch as shown.

NOTE: For best results, use aviation snips when cutting J-channel.

Cut top and bottom J-channels so the ends extend beyond the casing to the width of side J-channels.

Place top J-channel along the casing shoulder and nail it to the wall.

Make two cuts in the bottom of the upper channel and bend it down to overlap side J-channel. Repeat for the other side. This forms a water drain and allows J-channel to receive siding panel.

Nail the bottom J-channel in place. Cut the channel as previously described. Fold rain tabs into receiving pockets for a tighter miter joint.

To Miter Cut Corners

For best results, make sure you cut all J-channels to the proper length, leaving the proper allowance for the width of the face of the J-channel.

Square cut the bottom J-channel so that its ends extend beyond the window casing to the width of the face of the side J-channels. Notch the ends for clearance. Position and nail the J-channel.

Measure side J-channels, adding the width of both the top and bottom J-channels. Miter cut (45° angle) the lower ends of both side J-channels. Notch the channel, position and nail.

Mark the top J-channel so its ends extend beyond the casing to the width of the side J-channels. Miter cut (45° angle) the ends. Cut and bend water tabs. Position and nail.

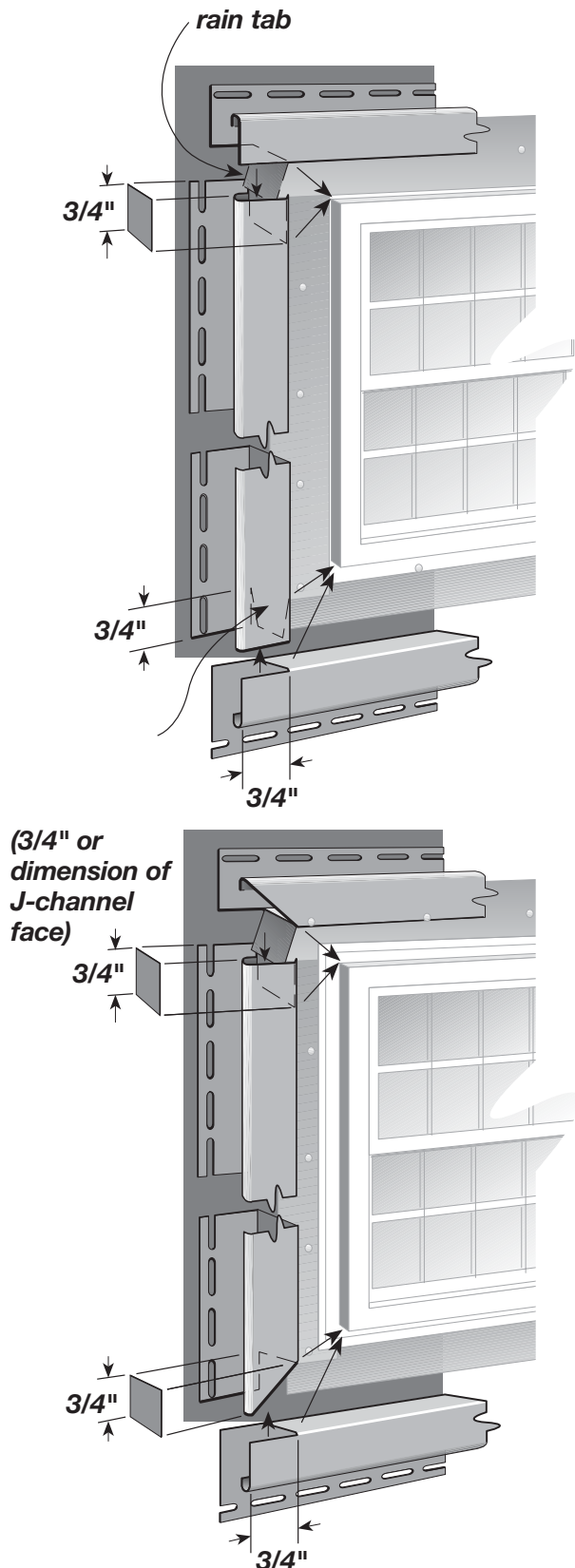

Drip Clip

The Drip-Clip is an easy and effective way to create rain tabs for lineals. To install Drip-Clips, miter lineals with a power miter box/chop saw, etc. Apply Drip-Clip to the top cut lineal. Slide the vertical lineal behind the vertical edge of the clip to complete the application.

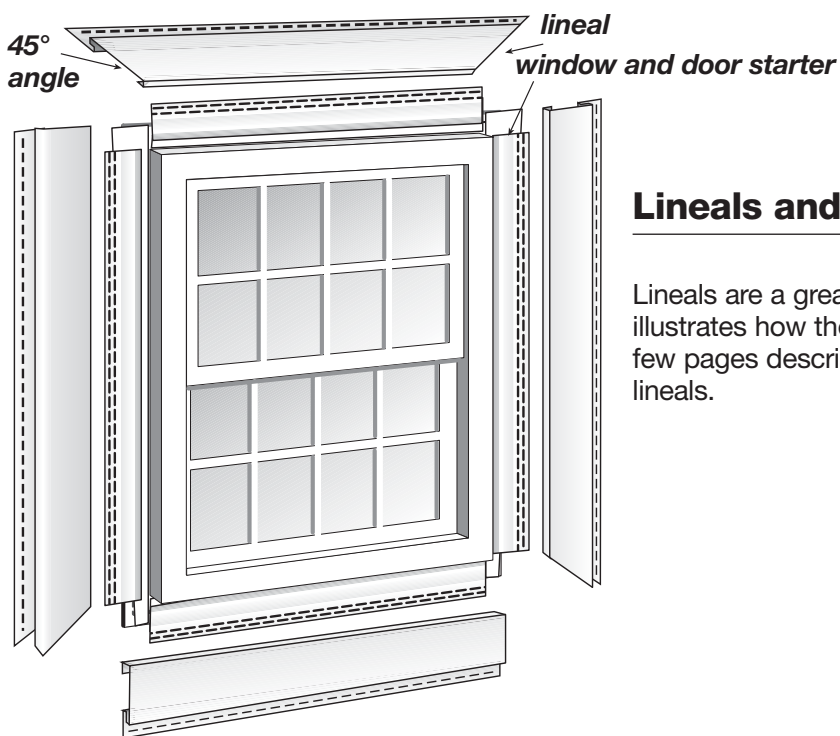
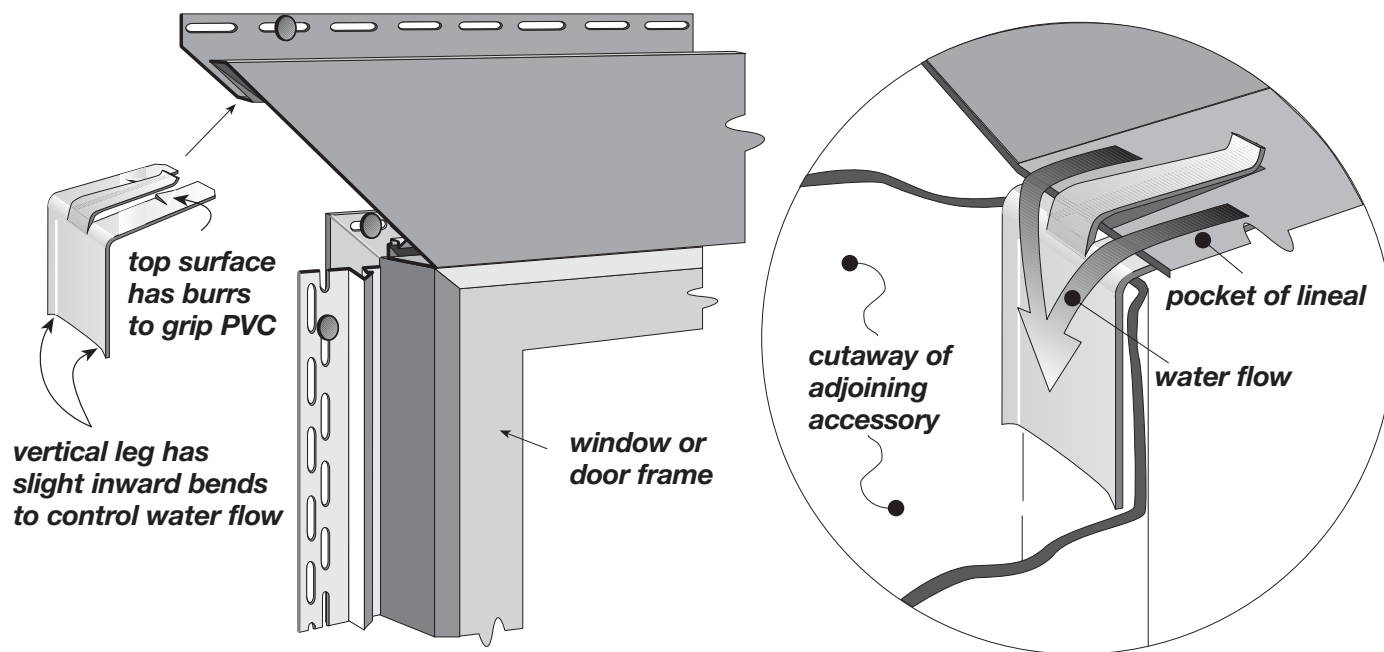

Lineals and Decorative Trim

Lineals are a great way to accessorize a window. This page illustrates how the lineal pieces fit around a window. The next few pages describe the step-by-step process for installing the lineals.

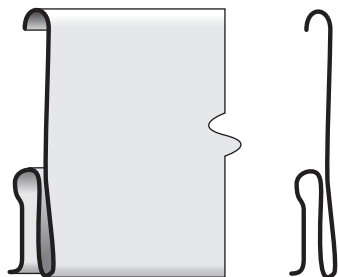

3-1/2" Snap-on Lineal Application around Windows and Doors

This application works only on 1"-faced J-channel.

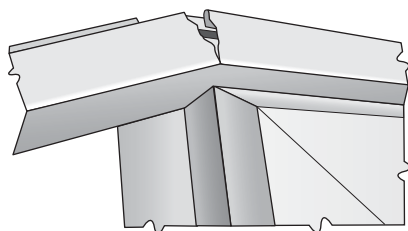

The installation of J-channel for snap-on lineals is the same procedure as installing lineal starter strip. Measure the openings and cut the J-channel 1/2" less than your measurement. Install the J-channel around the opening, centering the J-channel so that each end of the J-channel is 1/4" from the opening. Nail the J-channel every 8" to 10".

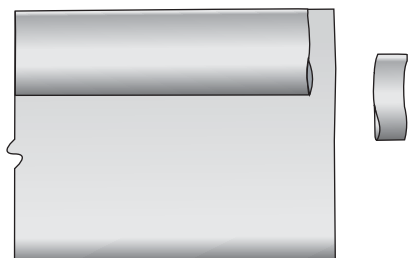
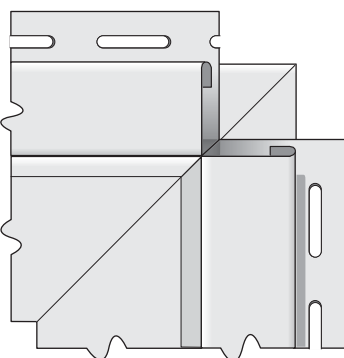

Lineal application around windows

Measure the top of the casing and add 7" (3-1/2" extra for each side). After the piece is cut to length, flip it over and cut 3/8" off the locking leg as shown.



Snap over the J-channel as shown.

Repeat for the bottom of the casing.

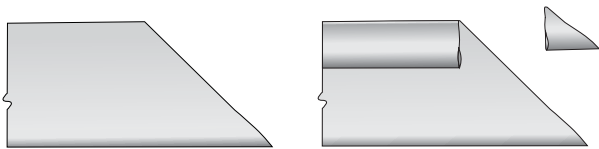

Measure the side casing and add 7". Use a triangle to create a 45° angle or measure 3-1/2" in from the edge of the part. Use snips or a miter saw to remove this portion.

Flip the part over and remove the locking leg as shown. This should be done to both ends.

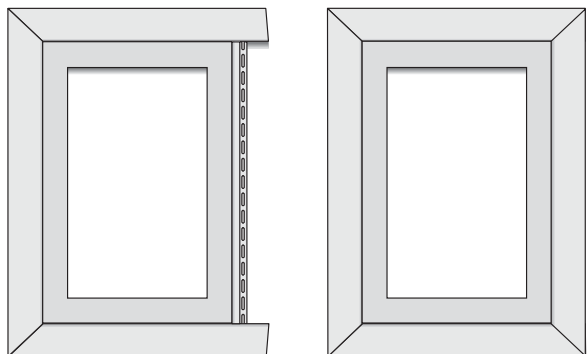

Snap the lineal over the J-channel as shown. Use the same measurements for both sides.

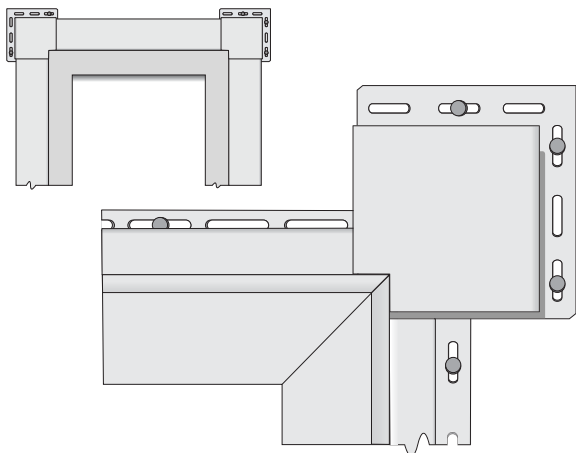

Corner blocks

Install J-channel around the perimeter of the window opening. J-channel should be the same length as the casing.

Install corner blocks on all 4 corners as shown. Leave blocks loose until the lineals are installed.

Cut the lineals the same length as the window casing.

Start with one end and angle a lineal into the corner block and snap it over the J-channel.

Continue installing lineals around the window.

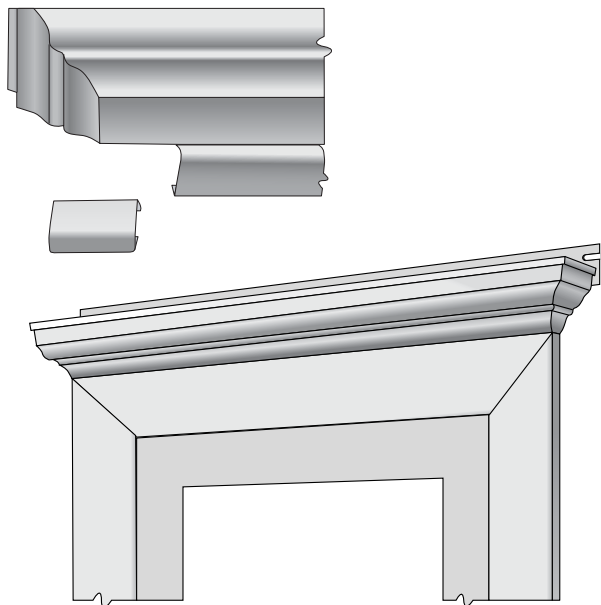

Crown molding

Crown molding will fit over the top of the lineal system.

Install J-channel and lineals around window casing.

Measure the top lineal and add 2-1/2". This will be the crown molding length.

Insert crown molding cap into the crown molding and trace the shape. Trim off the marked line.

The crown molding requires a tab 2" long – cut from the pocket receiver as shown.

Cut the crown molding cap in half and apply the halves with a bead of caulk.

Insert the crown molding into the top of the lineal as shown.

measure window and subtract 1/2"
(leaving 1/4" per side as shown)

vertical pieces: place the uppermost nail
in top of nail slot (still loose nailed)

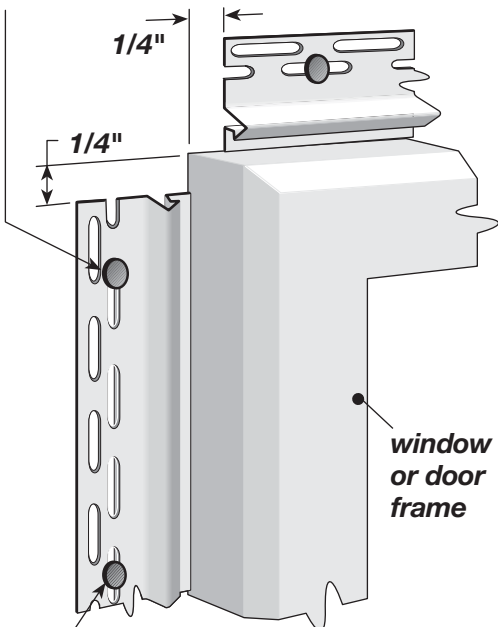

remaining vertical nails and all horizontal
nails: place in center of slots

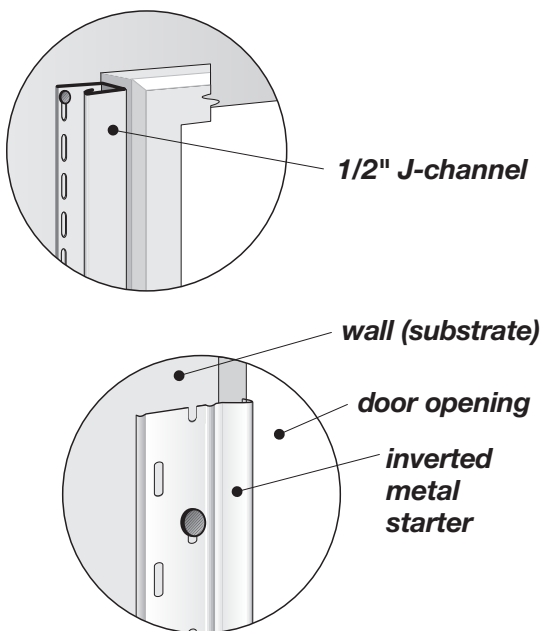

Lineal Starter Application for Windows and Door Surrounds

When securing window and corner starter strips, outside corner pieces (OSCP), inside corner pieces (ISCP), one piece corners, lineals – basically, any vertically mounted siding product – always place the top nail (or staple) first, and in a manner that allows the part to hang from it without dropping. This promotes movement downward only, a must for a good corner joint. **This is the only time you should not center a nail (or staple).** It is also preferred to use the nail slots closest to the locking area (when using product with double nail slots).

Remember to place the nails for the horizontal pieces in the center of the nailing slots as shown. Space nails 8"-10" apart.

Using a 1/2" J-channel as a starter for lineals.

NOTE: The lineals must be slid on from either end of the J-channel (the lineal will not snap over the J-channel as with a New Construction Starter Strip), or by pulling the J-channel away from the window slightly and zipping the lineal into place.

If the opening has no framework, such as a brick molding, use the metal starter (illustrated below left), or the Remodeling Window and Door Starter (illustrated below) in place of the New Construction Window and Door Starter Strip shown above. The lineal's locking leg will fit behind the aluminum starter and into the receiving pocket of the Remodeling Window and Door Starter.

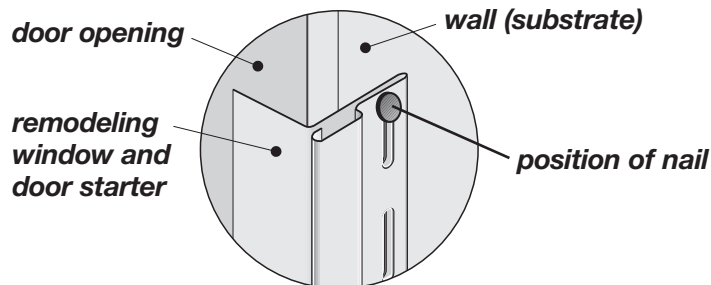

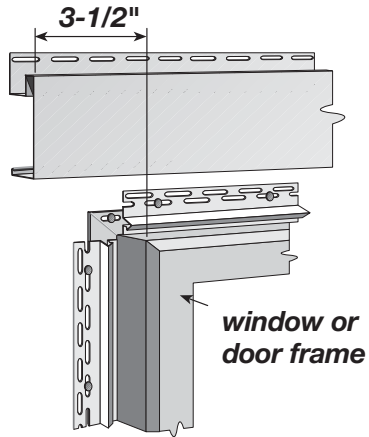

Lineal Application around Windows

Measure the top of the opening and add 7" (3-1/2" extra for each side) if the side lineals are also 3-1/2". Add 10" total if using 5" lineals.

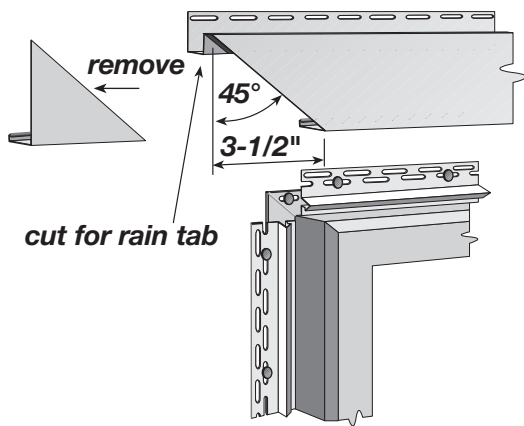

Use a triangle to create a 45° angle or measure 3-1/2" in from the locking leg.

NOTE: The nail flange is always the longest part of a surrounding miter.

Use snips to remove the part as shown.

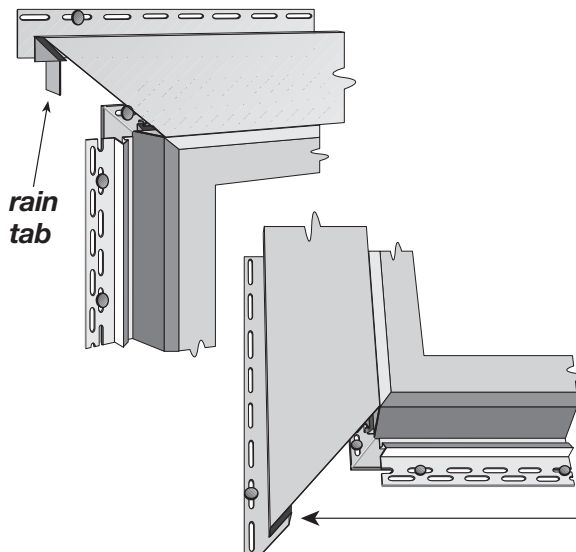
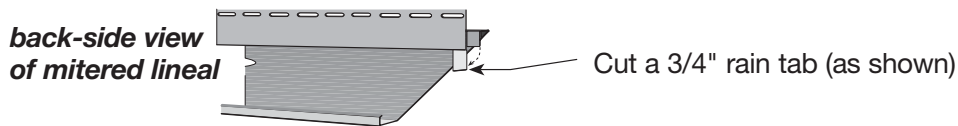

Completed top lineal snapped into the previously attached starter strip.

NOTE: The bottom miter of side lineals has the same cut as both ends of a top lineal; however, a rain tab is not required.

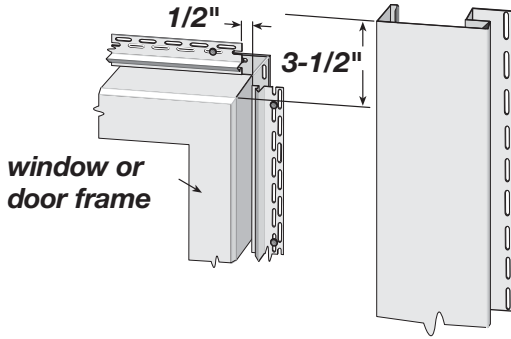

Measure the height of the window or door. Add 7" (for the 3-1/2" header and bottom lineal) and cut.

NOTE: Add additional material if using 5" lineals.

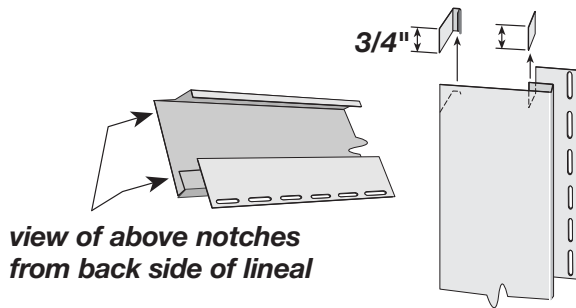

Trim a minimum of 3/4" from the top end of the side lineals.

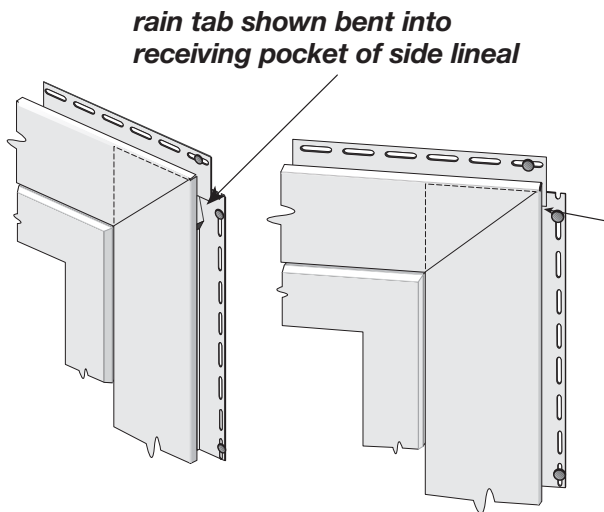

Snap the side lineals into place, making sure the rain tabs of the top lineal are bent down into the receiving pocket of the side lineals.

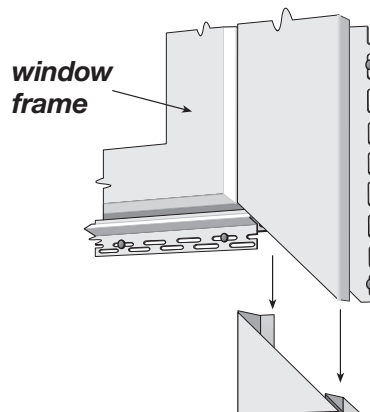

If the lineal surrounds a window frame, the bottom corner requires a 45° miter as done previously for the top lineal.

NOTE: Rain tabs are not required here.

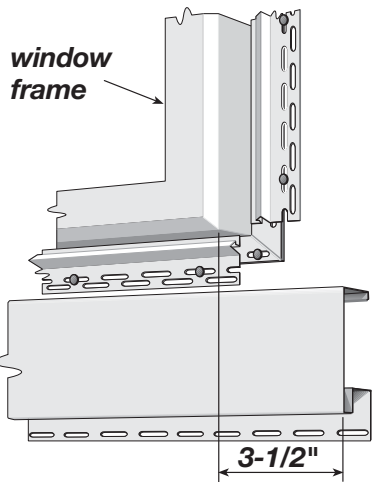

Measure the bottom of the opening and add 7" (3-1/2" extra for each side) if the side lineals are also 3-1/2". Add 10" total if using 5" lineals.

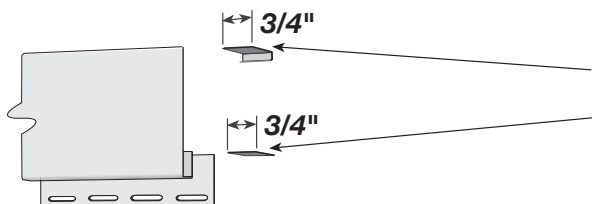

Trim 3/4" tabs from the lineal as shown.

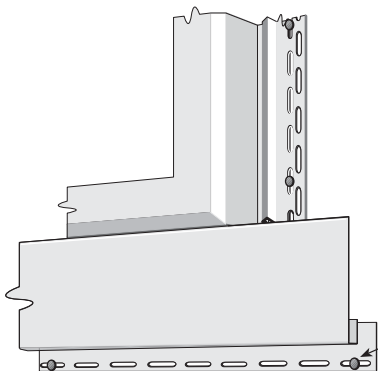
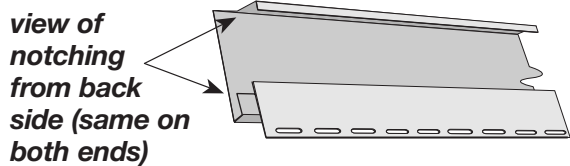

Snap the lineal in place and secure by nailing (or stapling) it through center of the nail slots.

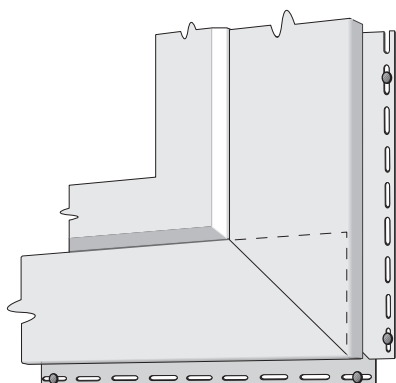

finished assembly with side lineal

Blind Miter

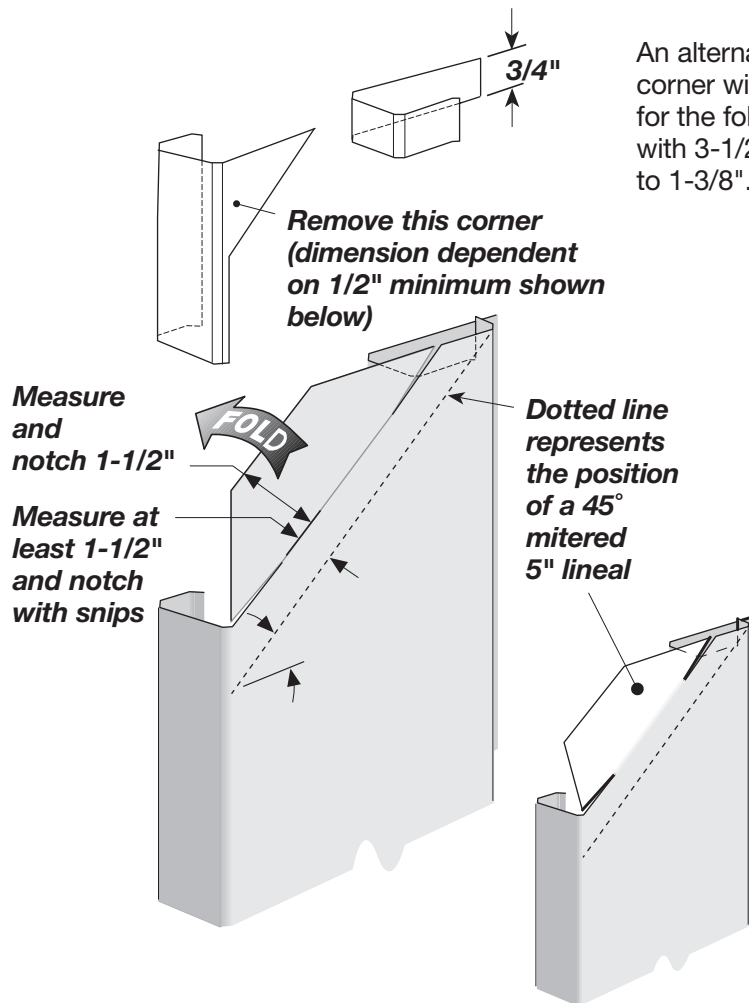

An alternative to a standard blind miter offers support to the corner without adding material. The measurements shown for the fold are for a 5" lineal. The same method can be used with 3-1/2" lineals, but the fold would be changed from 1-1/2" to 1-3/8".

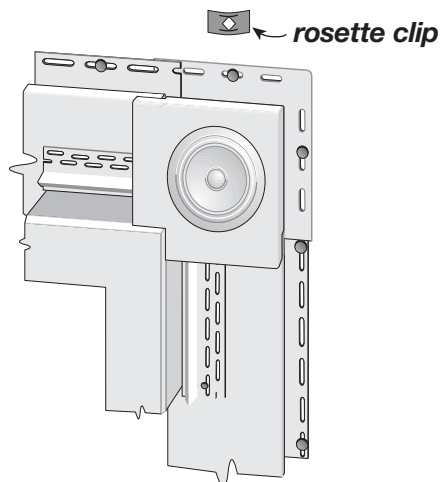
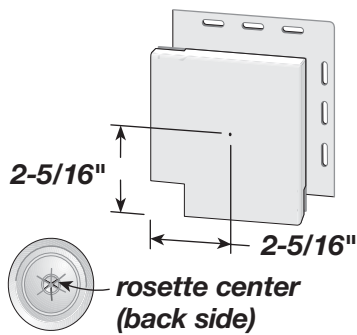
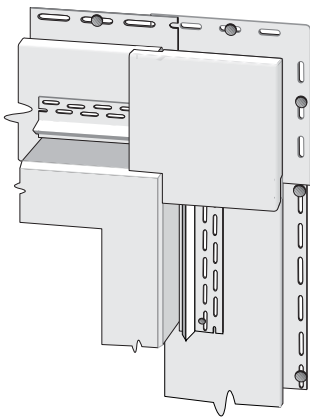
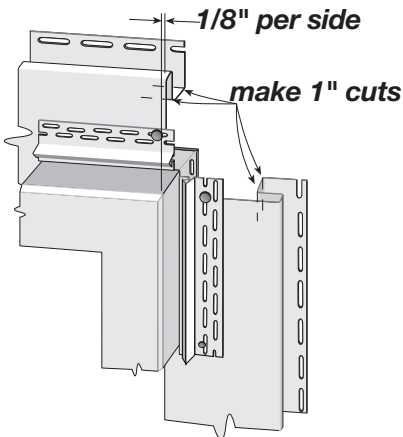

Corner Blocks

Corner Block

Install starter as previously described. Measure and cut the side lineals to the exact size of the window or door opening. Cut the top and bottom lineals 1/4" longer than the window.

Using vinyl snips, make two 1" long cuts in the pocket areas on both sides of each lineal. These cuts allow the lineals to connect with the corner block and help provide proper drainage.

NOTE: It may be helpful to hold off securing the lineals until the corner block is in place.

Position the corner block by inserting the top lineal into the corner block's receiving area – making sure the lineal's pocket is inside that of the corner block.

Position the vertical (side) lineal into the corner block by inserting the pocket of the corner cover into the pocket of the lineal. This will ensure proper drainage.

Corner Block with Rosette

Locate the small dimple on the back side of the block's face or measure 2-5/16" as shown and mark.

Drill or punch a 3/32" - 1/8" diameter hole through the face of the block – the hole must not be larger than 1/8".

NOTE: Check the back side of the block for this location – marked by "+".

Apply the rosette clip from the backside. If desired, a small amount of caulk can be applied over the hole prior to applying the rosette.

5" Square Header with Endcaps over 3-1/2" Lineals Sides and Bottoms

Assemble 5" header and cap. The side 3-1/2" lineals should extend approximately 1" inside the header assembly.

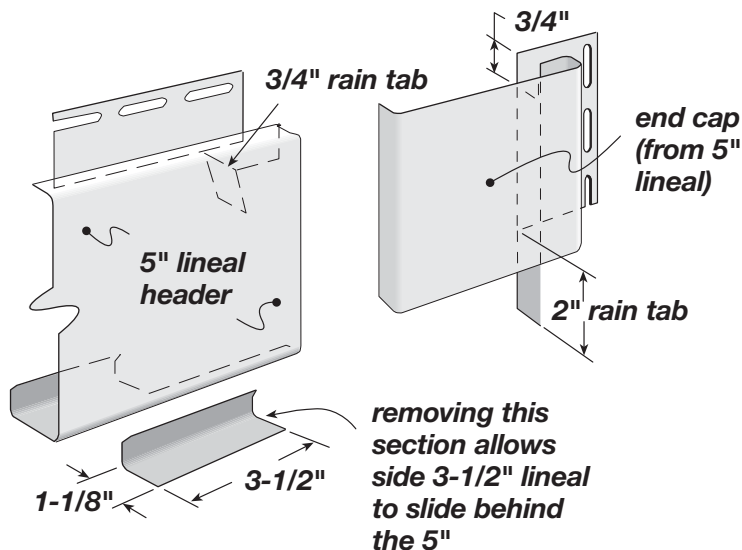

Finish the corner by sliding the 3-1/2" side lineals behind the header, making sure the 2" rain tab on the end cap extends into the receiving area of the side lineals.

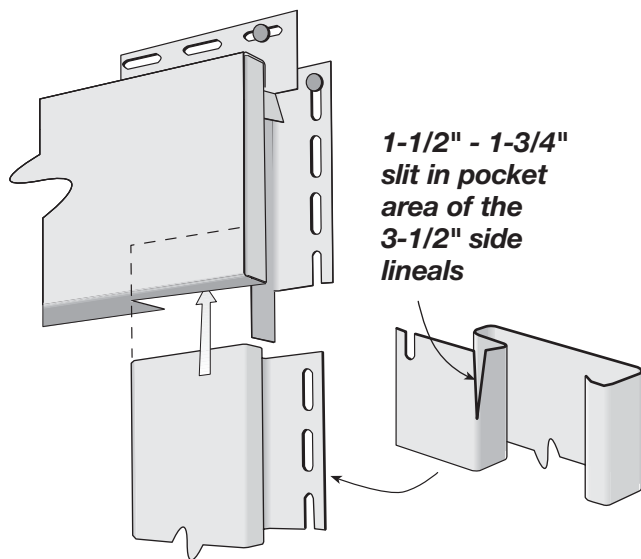

NOTE: If using crown molding, see page 50.

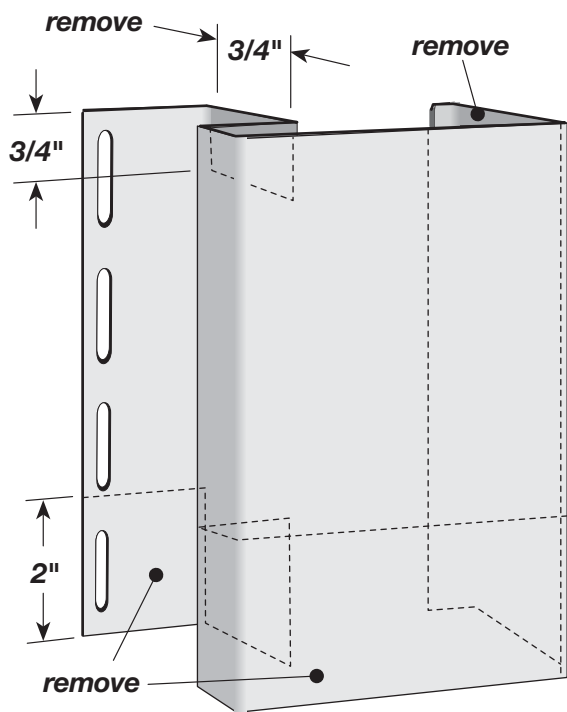

Creating End Caps for 5" Lineals

To create the header, first cut a 7" piece of 5" lineal. Measure and trim as shown.

The resulting piece fits into the end of the 5" lineal.

The ends of the 5" lineal also need trimming to receive the end caps. Create a 3/4" rain tab in the pocket area and trim off a 3/4" tab from the bottom.

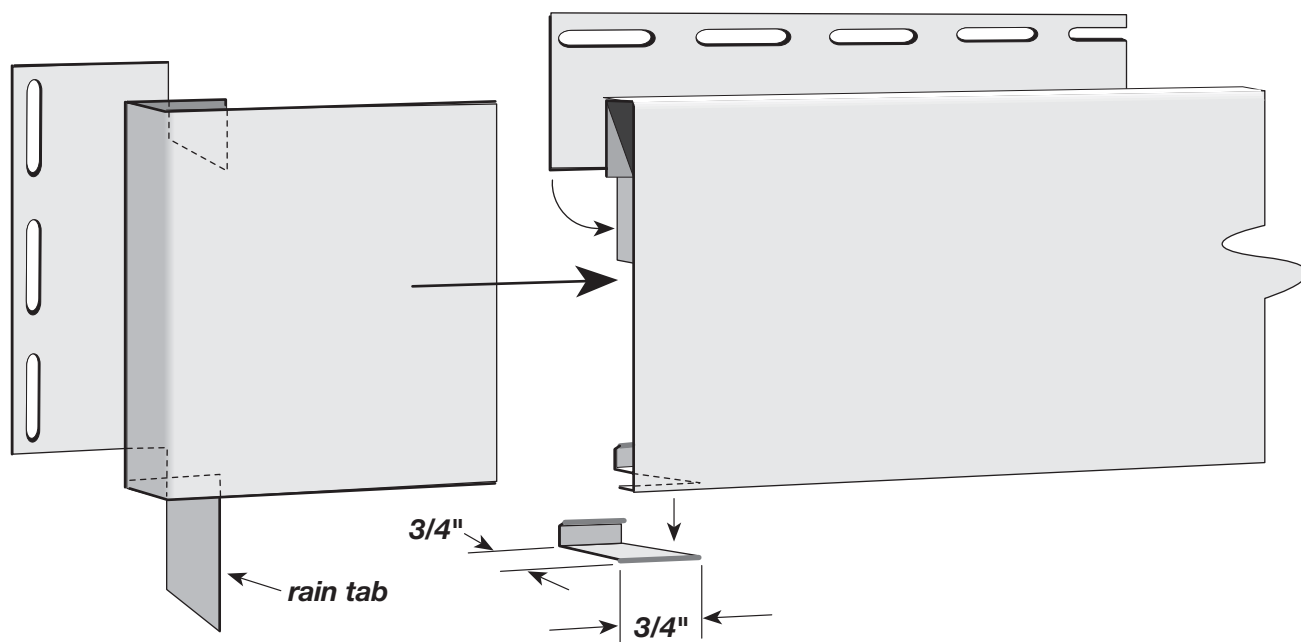

NOTE: To make end caps for 3-1/2" lineals, simply start with a 5-1/2" piece and remove the 3/4" and 2" areas as shown for the 5" end caps.

5" Angled Header with End Caps over 3-1/2" Lineals Sides and Bottoms

Assemble the 5" header and cap. The side 3-1/2" lineals should extend approximately 1" inside the header assembly.

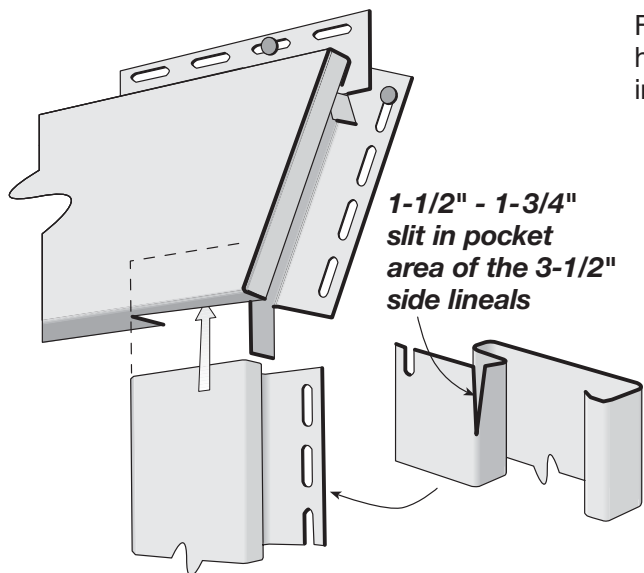
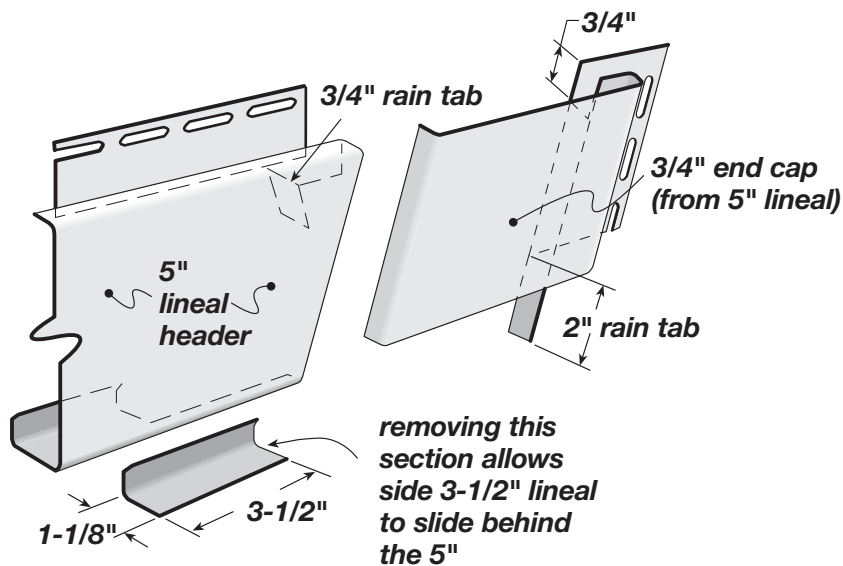

Finish the corner by sliding the 3-1/2" side lineals behind the header, making sure the 2" rain tab on the end cap extends into the receiving area of the side lineals.

Crown Molding Treatment Options

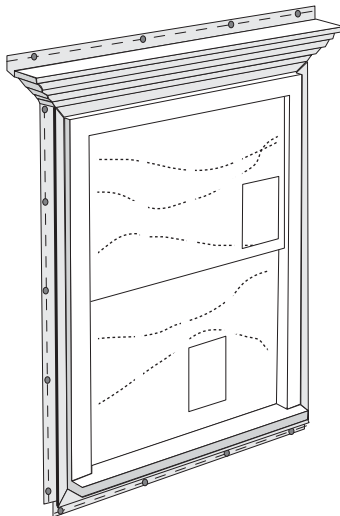

Option 1 (page 51)

- Crown molding
- (2) crown molding end caps
- 3/4" pocket J-channel header and surround

Other options are possible with the crown molding: For example, use 3-1/2" lineals vertically and at the window base along with a J-channel and crown molding header. The only requirement for using the crown molding is having receiving channels 3/4" wide.

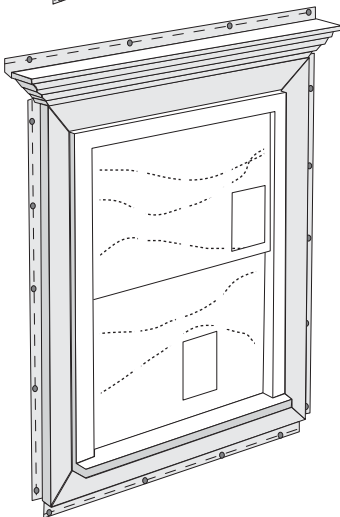

Option 2 (page 51)

- Crown molding
- (2) crown molding end caps
- 3-1/2" lineal header
- 3-1/2" lineal surrounds

NOTE: *Corner blocks/rosettes can be used to join lineals at the corner.*

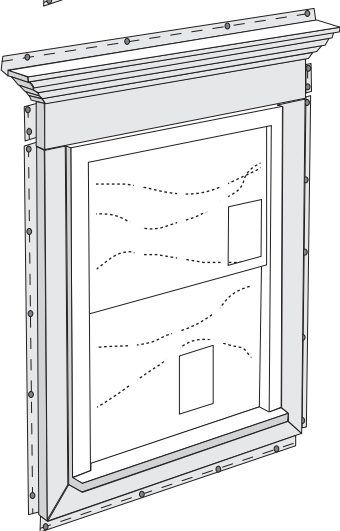

Option 3 (page 52)

- Crown molding
- (2) crown molding end caps
- 5" lineal header
- (2) 5" header end caps
- 3-1/2" lineal surrounds

Instructions for each option are on pages 51-53.

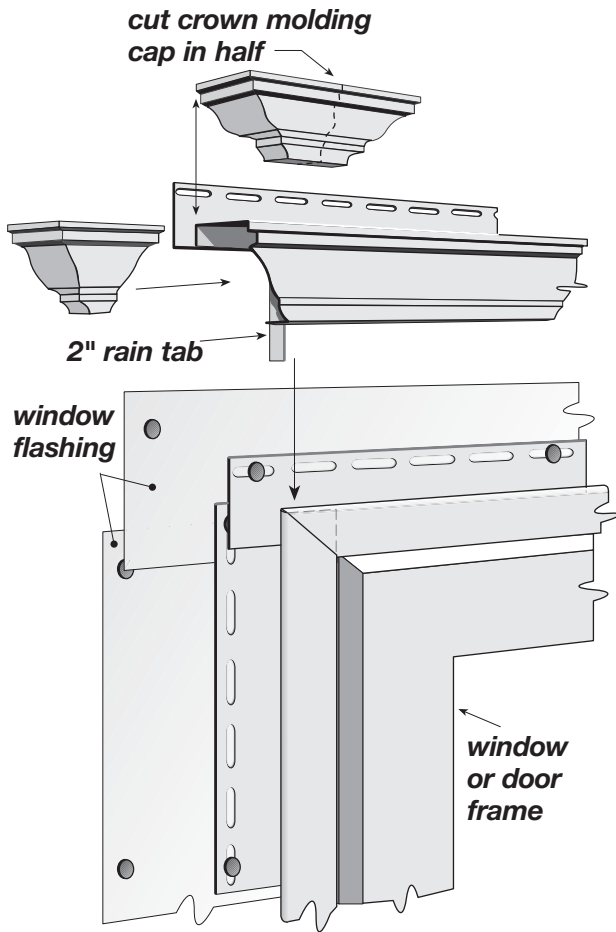

Crown Molding and Cap for 3/4" Pocket J-channel

To use crown molding with 3/4" pocket J-channels, measure the length of the completed J-channel surround and add 2-1/2" (the crown molding overlaps the J-channels by 1-1/4" per side).

Insert crown molding cap into the crown molding and trace the tip shape. Trim as shown.

Insert 1/2 of the crown molding cap into each end of the crown molding lineal. Secure the crown molding with a bead of caulk.

Miter or square cut the J-channel (mitered corner shown). Insert the 3/4" wide rain tab into the receiving channel of the side J-channel.

insert cap
(see above for instructions
on assembling the cap)

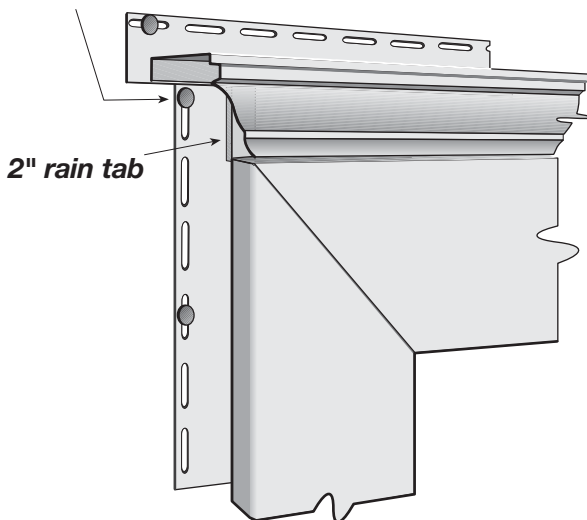

Crown Molding with 3-1/2" Lineal Surround

In addition to J-channel, crown moldings can also be used with lineals. The next two pages demonstrate how crown molding can be used with various lineal configurations. Above all, remember that before applying accessories and siding, make certain the substrate is watertight. In order to be properly protected from precipitation, the substrate may need to be properly flashed to shed water to the exterior. The siding alone is not meant to be a watertight barrier.

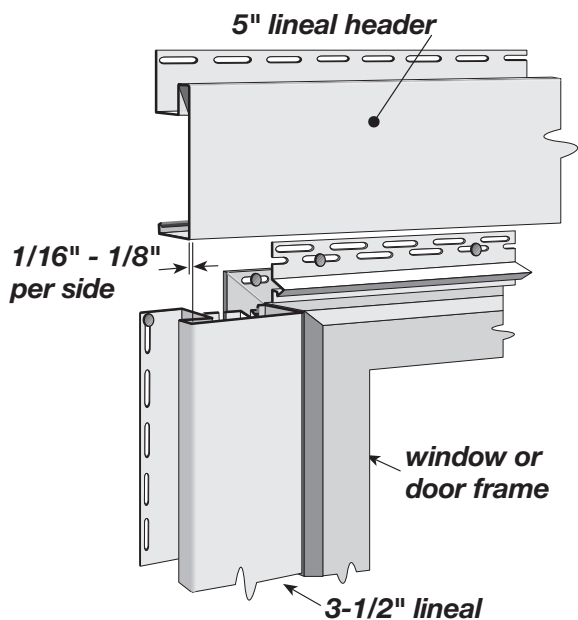

Crown Molding with Cap for 5" Header Lineal

Crown molding with 5" header and 3-1/2" surrounds.

Determine the header length by measuring from the outside of both side lineals and adding 1/16"-1/8" per side for overlap.

To cut the crown molding, add 2-1/2" to the previously determined header length (1-1/4" added per side).

To create the header end cap, cut a 9-1/4" piece of 5" lineal and trim as shown.

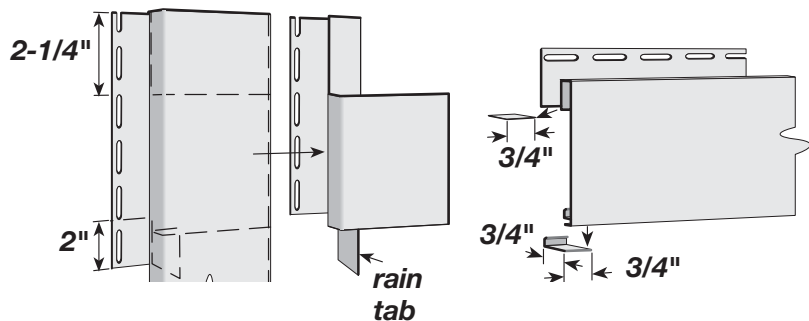

Notch both ends of the header as shown.

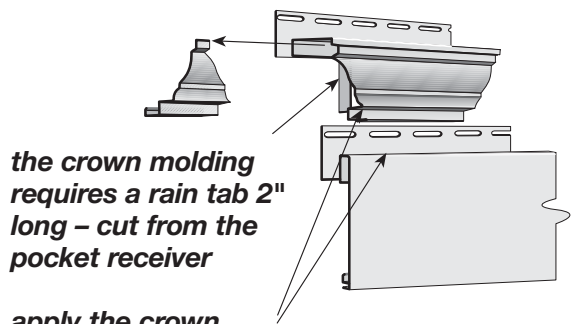

the crown molding requires a rain tab 2" long - cut from the pocket receiver

apply the crown molding to the header with a bead of caulk

Insert a crown molding cap into the crown molding and trace the shape. Trim as shown.

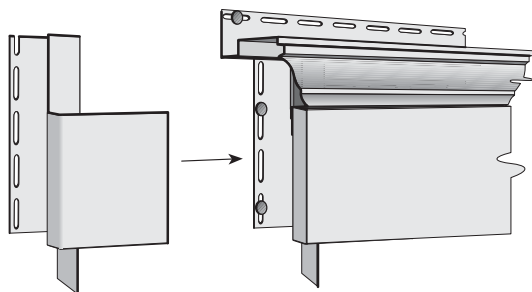

Insert the header cap.

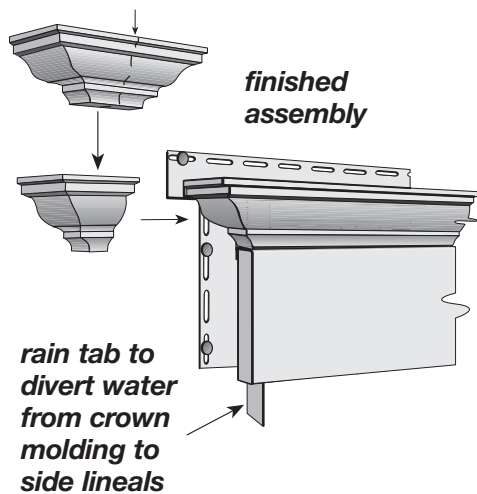

finished assembly

rain tab to divert water from crown molding to side lineals

Cut the crown molding cap in half. Apply each half to the end of the crown molding and secure it with a bead of caulk.

Installing J-channel as Gable End Trim

Install J-channel to receive siding at gable ends, as shown in illustration. To create a clean, professional look, follow these steps:

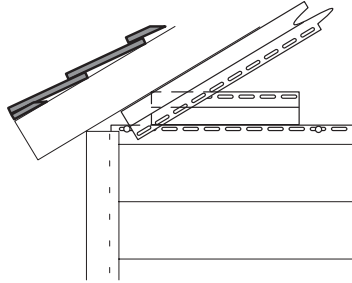

To create an angle template, hold a piece of J-channel against the slope while transferring the angle to another J-channel with a pencil.

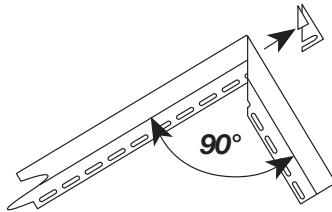

Next, transfer angle of template to the end of a length of J-channel. Be sure to extend line onto nail flange. Cut away channel face and nail flange.

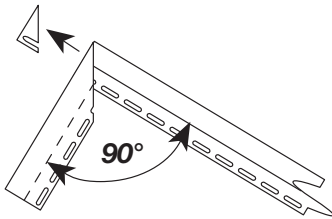

Turn pattern over and transfer opposite angle to second J-channel, being sure to extend line onto nail flange. Cut away nail flange and return lip, but do not cut J-channel face.

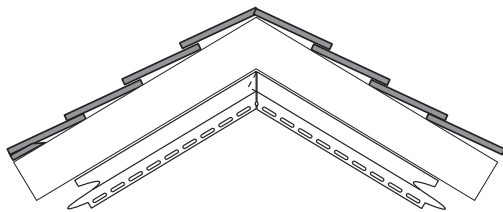

Insert the full-faced J-channel into the mitered J-channel. If the nail flange or return lips butt and prevent a tight fit, trim off additional material from the second J-channel.

NOTE: For a more decorative appearance, you also can use 3-1/2" or 5" lineals to trim gable ends (see next page for details).

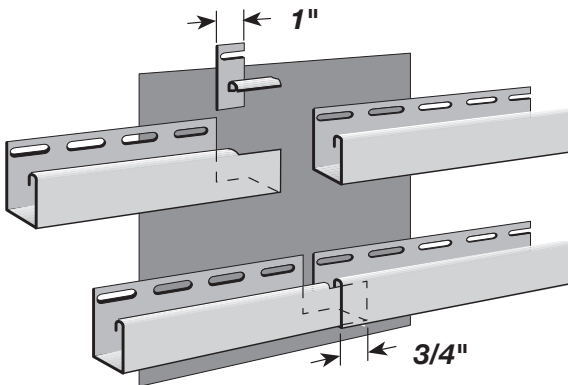

To splice the J-channel, follow these steps:

Cut out a 1" section of the nailing flange and face return as shown.

Install inverted J-channel along the top of the wall, under the eave. Here again, leave a 1/4" gap between J-channel and cornerposts. Overlap J-channels 3/4" to allow for expansion. When positioning the upper J-channel, be sure to allow for expansion of the siding panel. In most cases, position the J-channel at a point equal to the length of the panel plus 5/8" (1/4" for upper expansion and 3/8" for lower expansion).

Using Lineals as Gable Trim

You can give gable end trim a more dramatic appearance by using 3-1/2" or 5" lineals instead of J-channel.

To install the lineals:

Make a pattern duplicating the gable slope. To create an angle template, lock a piece of lineal into the previous course of siding or other gable starter. Hold a second piece of lineal or starter against the slope and transfer the angle with a pencil.

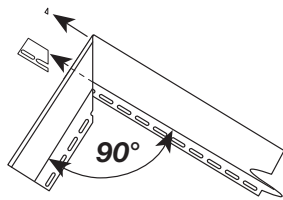
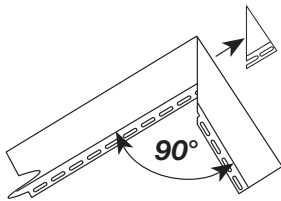
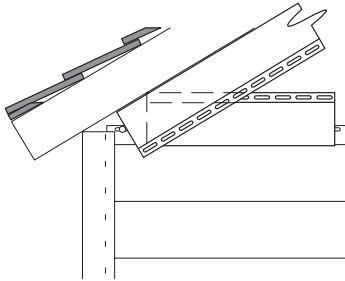

Transfer the angle of the template to the end of a length of lineal. Cut away lineal face and nail flange.

Turn pattern over and transfer opposite angle to second lineal. Trim nail flange and receiving channel from opposite lineal to this line. Do not cut lineal face.

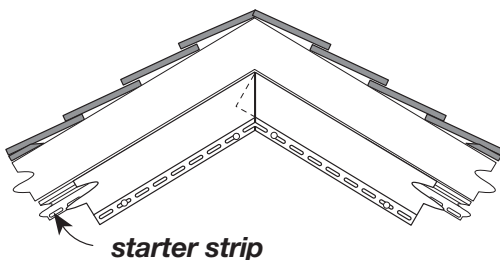

Insert the full-faced lineal into the mitered lineal. If the nail flange or return lips butt and prevent a tight fit, trim off additional material from the second lineal.

Installing trim at roof line

To prevent water infiltration along the intersection of roof and wall, install flashing before installing J-channel. At points where vinyl siding and accessories will meet at a roof line – such as areas where a gable dormer or a second story side wall intersect with the roof – it's best to position the J-channel so it's 3/4" to 1" away from the roof line. Placing the J-channel directly on the roof line would subject it to a build-up of heat, which could result in excessive expansion.

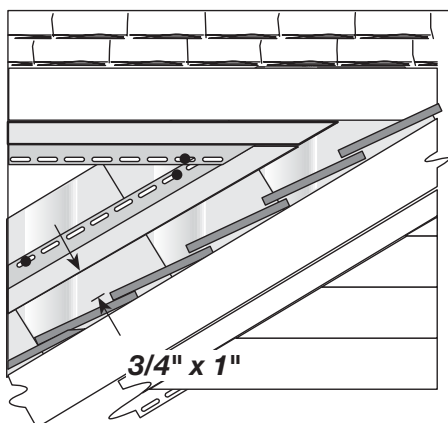

NOTE: If you use more than one length of J-channel to span a wall surface, be sure to overlap J-channels 3/4".

SECTION 5 - Installing Horizontal Siding

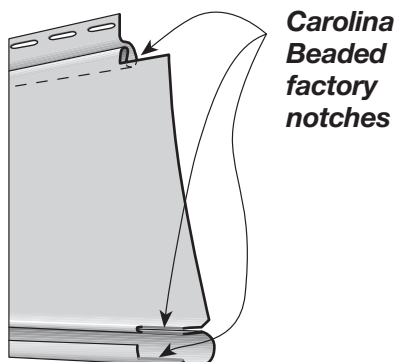
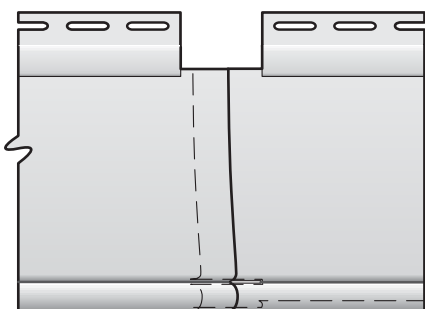
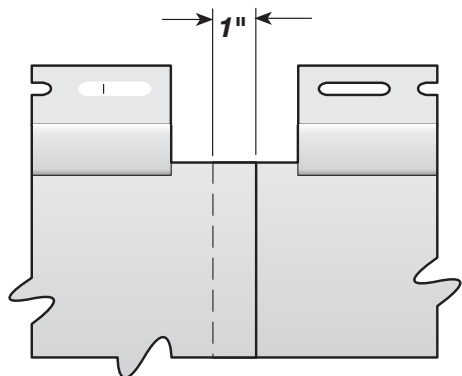
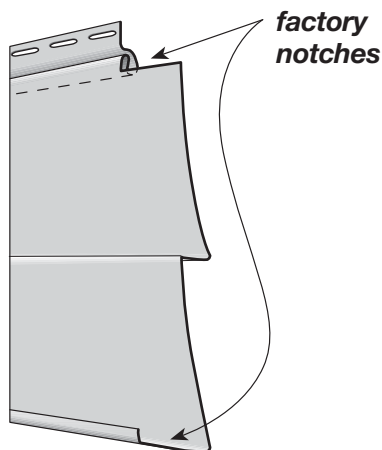

Cutting Panels

To cut panels to size, follow these procedures:

Cross cuts

For a precise cut, use a power circular saw equipped with a sharp, fine-tooth plywood blade. For best results, reverse blade direction.

Cut one or two panels at a time, carefully advancing the saw through the vinyl. A rule of thumb: The lower the temperature, the slower the feed rate.

Panels can also be cut with snips. Use a square to mark cut line. Start cut at top lock and continue to bottom of panel.

NOTE: *Whenever you cross cut a panel to be used in an overlap area, you also have to duplicate the factory notch at the cut end.*

Rip cuts

Use a utility knife to score panel along cut line. Bend panel back and forth along score line until it snaps apart cleanly.

Use a combination of tin snips and utility knife to cut panels to fit around windows and doors.

Overlapping Panels

When lapping horizontal panels, overlap the ends 1".

NOTE: *Carolina Beaded, Restoration Shapes 7" Shakes, and 10" Hand-Split Shakes are factory-notched. Overlap panels using factory notched ends only.*

Preparing Wall Surfaces

The key to successful vinyl siding application is proper preparation of the nailing surface. It is essential that you work over a smooth nailing surface. The more level and even the wall surface, the better the finished installation will look.

The steps involved in preparation differ for new homes and old, so choose the instructions (page 21) that pertain to your project.

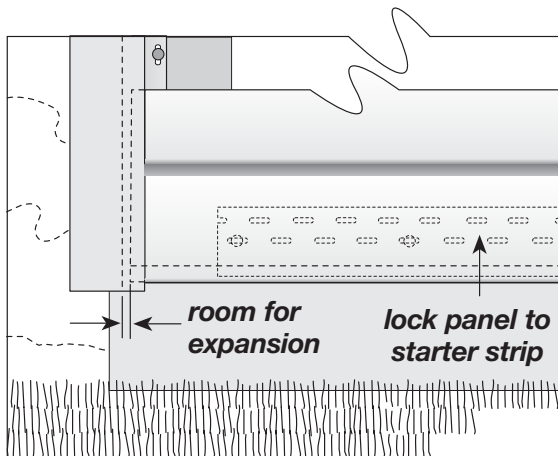

Installing the First Course

It's important to work with care and planning as you install siding panels. This is especially true when you're installing the first course of siding. (See pages 24-25 for fastening methods.)

For best results, follow these guidelines:

The key to creating a visually attractive installation is to **lap away** from areas where people normally walk or gather. For example, on the front wall, work from the corners to the entrance door (so overlaps face away from door). On side walls, work from the rear corners toward the front. This approach minimizes the effect of lapping and produces the best appearance. Keep lap appearance in mind throughout installation.

NOTE: Lap appearance is also improved when you avoid using panels less than 3' long.

Slide the first panel into the cornerpost recess. Leave room for expansion (see page 26).

Hook the bottom lock of the panel into the interlock bead of the starter strip by applying upward pressure.

Before nailing, double check to make certain you've locked the panel along its entire length. A slight upward pressure may be required to snap the interlock securely. Don't force the lock too tightly, however. You may distort your laps. Also, make certain the panel can slide freely. Nail properly. Start at the center of the panel and work out.

Install the remaining starter course panels, overlapping panel ends 1". The last nail should be at least 4" from the end of the panel to allow for a neat lap.

Remember to leave room for expansion when fitting panels into remaining inside and outside cornerposts.

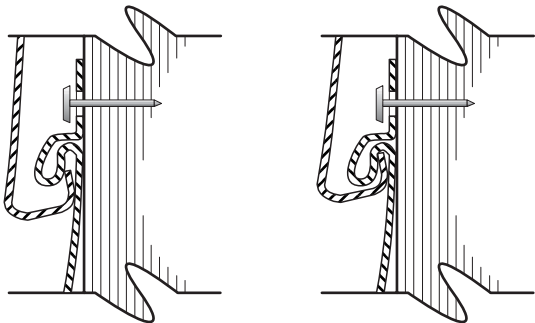

lock not fully engaged **lock fully engaged**

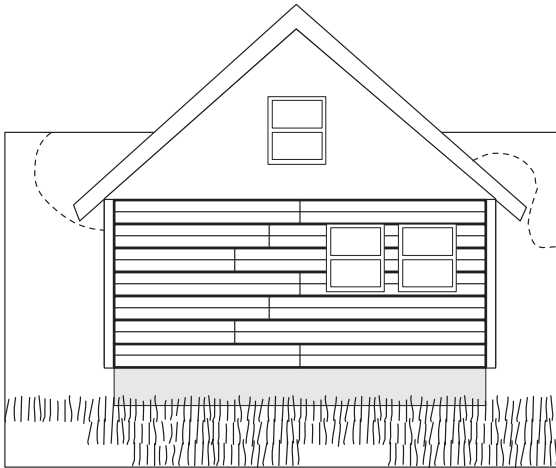

Installing remaining courses

To ensure best appearance, position the laps to avoid unsightly joint patterns. The illustration at left shows a well-planned staggering of panel joints. Follow these guidelines:

Separate joints by at least two courses.

Avoid joints above and below windows.

Leave at least 3' separating joints on successive courses.

Use short cutoff lengths for fitting at narrow openings between windows.

Follow the planned pattern when applying the next courses of siding.

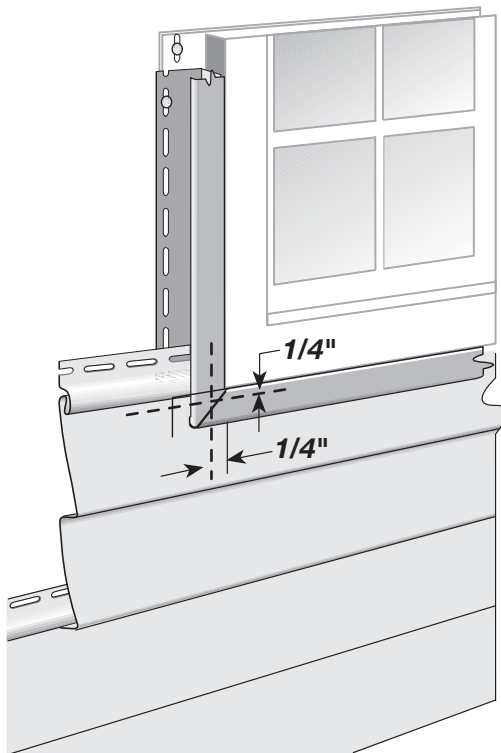

Fitting under windows

You'll probably have to cut panels to fit under windows. To make this task easier, plan panel positioning as shown at left so a single panel extends beyond both sides of window opening. Follow these steps to measure and cut panels:

Hold panel in place and mark the width of window opening. Add 1/4"-3/8" to both ends to allow for expansion. The resulting marks show location of vertical cuts. Extend marks onto panel using a square.

Create a template for horizontal cut using small piece of scrap siding. Lock this piece into the lower panel and mark 1/4" below sill height. This provides clearance for undersill trim. Repeat procedure on opposite side of window. (You can't assume windows will be perfectly level.)

Transfer marks from template to panel. Connect marks using straightedge.

Cut panel, using tin snips to make vertical cuts and a utility knife to make horizontal cut.

Install panel

If necessary to maintain slope angle, install furring under sill as described on page 22.

NOTE: You can eliminate this step by using dual undersill trim. This trim has two receiving channels. Use the inner channel if you've cut the siding panel near the locking edge. Use the outer channel if the cut has been made near the butt edge.

Use a snap lock punch to raise tab faces on the outside of the panel. Punch out tab every 6".

Push horizontal edge of cut into utility trim. Slide vertical edges of cut into J-channels at window sides. Make certain the installed panel locks into the panel below.

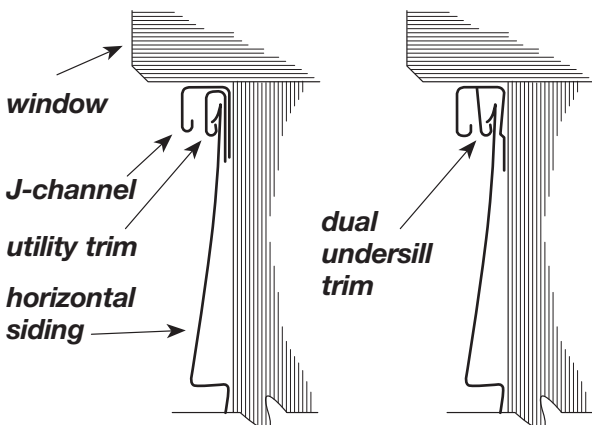

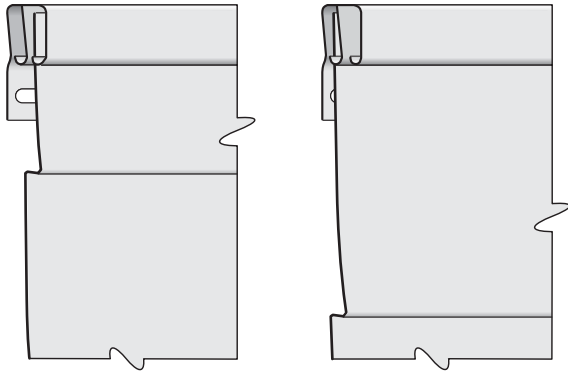

**installing trimmed panels
with dual undersill trim**

Fitting over windows and doors

The procedure for cutting panels for installation over windows and doors is similar to that explained earlier.

If necessary to maintain slope angle, install furring above window or door as explained on page 22.

Drop panel into position, making certain it fits into undersill trim and J-channel at top and J-channels at sides. Interlock with the siding panels below.

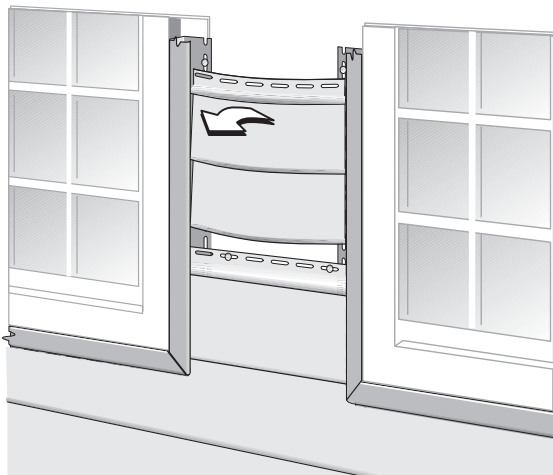

Fitting at narrow openings between windows

To simplify installation in areas such as that shown in the illustration, install J-channels on both sides of opening. Bow the panel toward you and slip into channel.

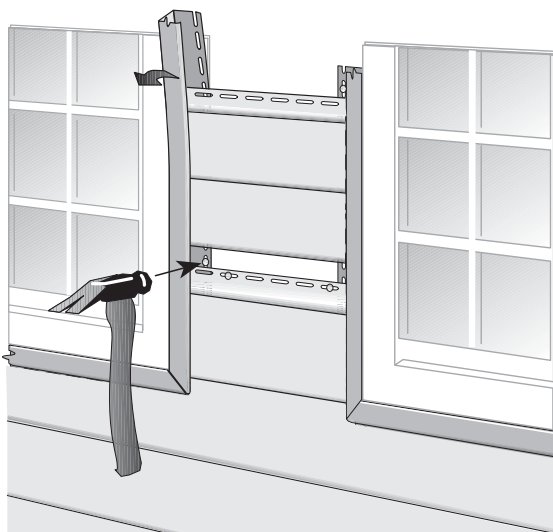

If the area is very narrow, leave one J-channel unnailed except at lowest point (as shown). Bend this channel out slightly to insert panel. When panel is in place and nailed, nail J-channel immediately above panel and repeat procedure. Be sure to leave adequate tolerances for expansion and contraction.

STUDfinder Installation System

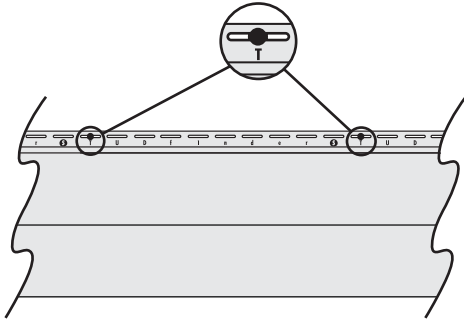

The STUDfinder™ Installation System combines precisely engineered nail slot locations with graphics to create a siding panel that is designed to help ensure quick, accurate and secure installation.

The nail slots are positioned 16" and 24" on center to allow for alignment with studs, with STUDfinder graphics centered directly under each nail slot.

Locate the first stud and fasten in the center of the nail slot. Ensure that nail/staple penetration is at least 3/4" to comply with ASTM D4756 (specification for vinyl siding installation). Notice which STUDfinder letter appears below the slot.

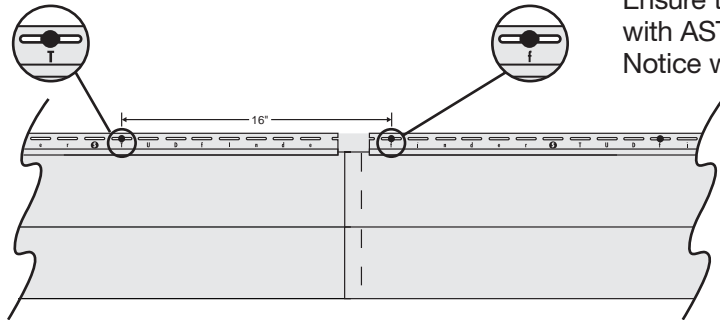

Go to the next repeat of the letter to find the next stud. For example, if your first stud is at "T," so will the succeeding studs in 16" o.c. applications (every 10th slot).

When you apply the next panel, adjust the overlap, as necessary, to line up with studs and repeat the steps above.

24" o.c. applications will use a similar pattern of letters, with 2 letters that repeat every-other stud (every 15th slot). For example, if the first stud is located at "S," then the next will be at "l," then "S," then "l," etc.

NOTE: The overlap must be a minimum of 1" - 1-1/2". The overlapping panels may not use the same letter as your initial panel.

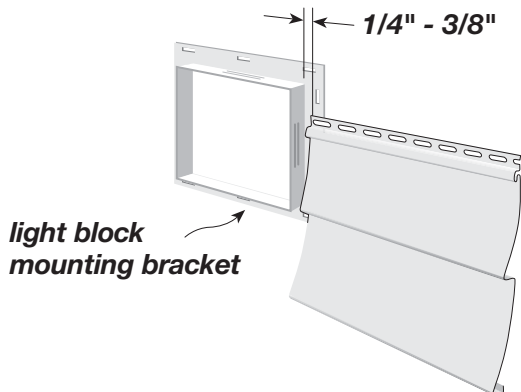
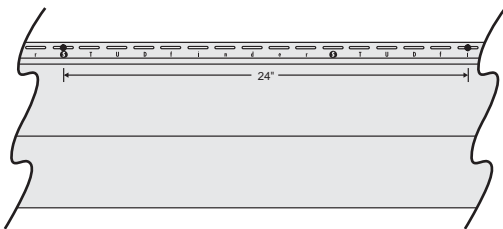

Fitting at light blocks

When cutting panels to fit at a light block, be sure to allow for expansion.

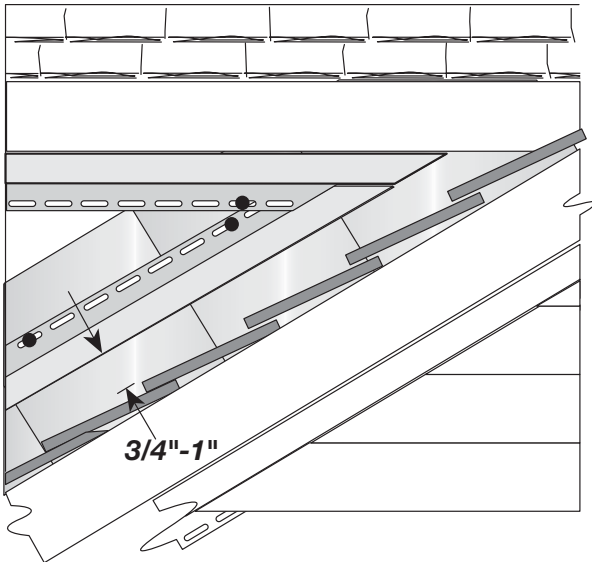

Installing trim at roof line

To prevent water infiltration along the intersection of roof and wall, install flashing before installing J-channel. At points where vinyl siding and accessories will meet at a roof line – such as areas where a gable dormer or a second-story side wall intersect with the roof – it's best to position the J-channel so it's 3/4" to 1" away from the roof line. Placing the J-channel directly on the roof line would subject it to a buildup of heat, which could result in excessive expansion.

NOTE: *If you use more than one length of J-channel to span a wall surface, be sure to overlap J-channels 3/4".*

Do not butt J-channel pieces end-to-end.

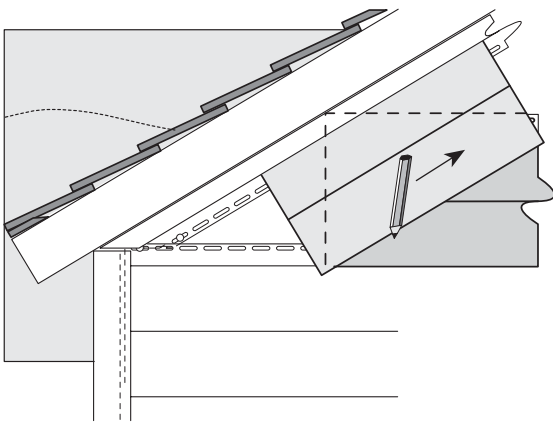

Fitting at gable ends

Make a pattern duplicating gable slope. Use this pattern to guide cutting of panels to fit gable ends.

To make pattern:

Lock short piece of siding into panel gable starter course as shown in illustration.

Hold second piece of siding against J-channel at slope. Run pencil along edge of this piece, transferring slope angle to first piece of siding.

Cut along line using power saw or tin snips. Use resulting pattern to mark siding panels before cutting.

NOTE: *Double-check angle on pattern at every course. If necessary, cut new pattern.*

To install cut panels:

Slip angled end of panel into J-channel along gable edge. Leave space for expansion.

Interlock with siding panel below.

If necessary to securely fasten the last panel at gable peak, face nail as shown in illustration. This is the only place you will face nail. Use 1-1/4" to 1-1/2" aluminum nail with painted head.

NOTE: *Do not cover louvers in gables.*

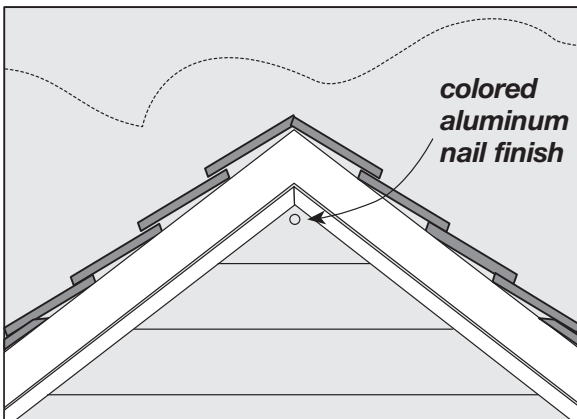

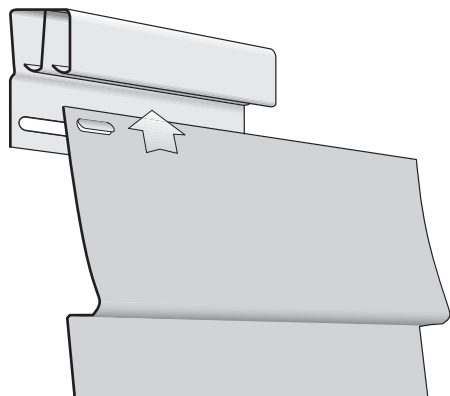
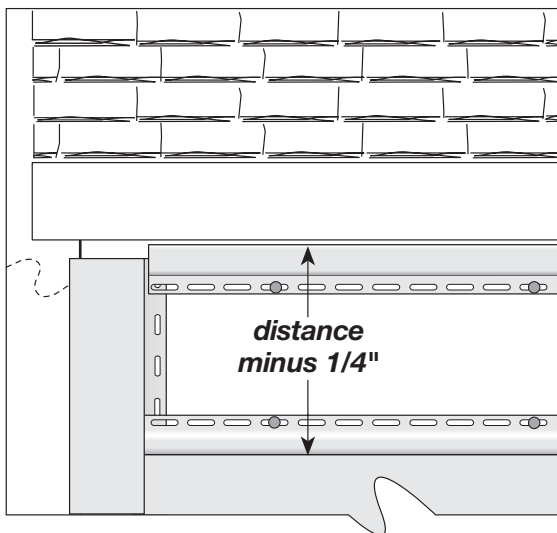

Fitting under soffit

When you reach the last course of siding, you will probably have to rip cut panels lengthwise to fit under soffit.

NOTE: If necessary to ensure proper panel slope angle, make certain to furr out this area.

To cut and install this last course:

Install J-channel and undersill trim or dual undersill.

Measure from soffit to base of upper lock on previous course of panels. Subtract 1/4". Mark this dimension on the panel to be cut, taking measurement from bottom edge of panel. For a more precise cut, repeat this procedure at several other points along the span to be covered by the panel.

Using a square or straightedge, draw a pencil line connecting these points. Then score along line with utility knife. Bend panel back and forth until it snaps.

Use snap lock punch to create tabs on outside face of panel, 1/4" below cut edge. Space tabs every 6".

To install, lock bottom of cut panel into panel below. Push top edge into J-channel or undersill trim. Tabs will catch in trim and hold panel firmly in place.

NOTE: Since you will not nail this last course, it is important that the tabs fit properly in the trim to provide support while allowing movement for expansion.

Completion

Attaching objects to siding

All external products (downspouts, shutters, and lights, for example) are attached to walls after you've applied the vinyl siding.

NOTE: All external fixtures must be attached to a solid backing (such as 3/4" exterior grade plywood) to provide a secure mounting surface. Never attach a fixture directly to vinyl siding.

When installing external products, you must allow for expansion and contraction of siding.

You can allow for this movement in two ways:

The most convenient way to attach light fixtures is with light blocks. Because they contain receiving channels to hold siding panels, light blocks provide a simple way to allow for expansion.

When attaching other fixtures, drill holes in the siding three times the diameter of screws, bolts, or nails being used to fasten objects. This provides adequate clearance so siding **can move freely underneath attached objects**. When attaching objects, do not fasten tightly. It is also recommended that you apply caulk around the screws.

Shutter Installation

(A) The ideal application (shown at the top) has a joint between the two shutters where the shutters are secured to the home. In this way, the siding panel is not “hard nailed” between the two shutters and the siding is allowed free movement.

Enlarge the hole in the siding for securing the shutter – the hole clearance should be approximately 1/8". If possible, stagger the screws securing the shutter so that they do not line up on the same panel. It is also a good idea to apply caulk around the screws.

A

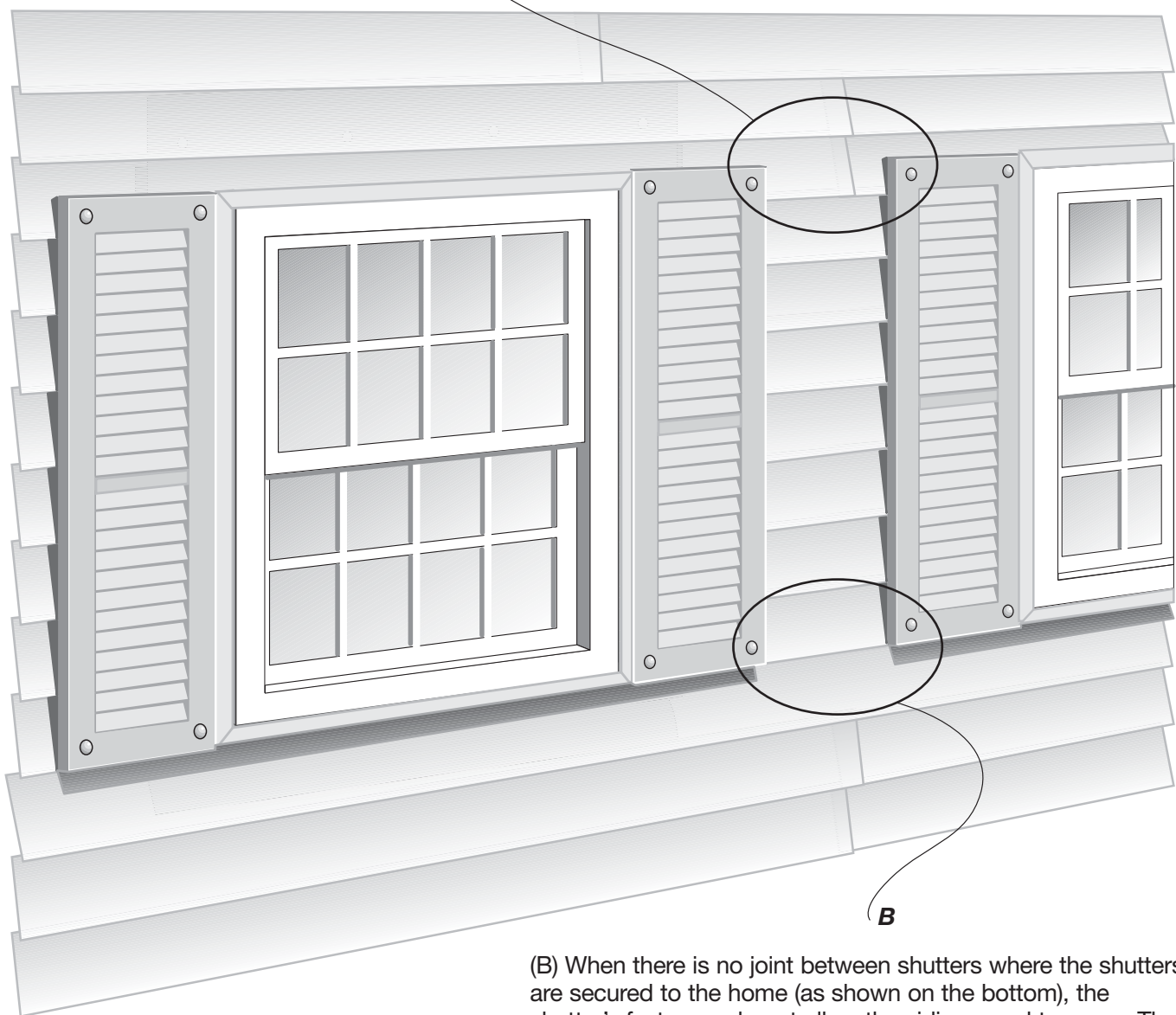

(B) When there is no joint between shutters where the shutters are secured to the home (as shown on the bottom), the shutter's fasteners do not allow the siding panel to move. The siding panel then fails to perform because it cannot expand or contract with the temperature changes.

SECTION 6 – Installing Vertical Siding

upper edge of topmost
nailing slot

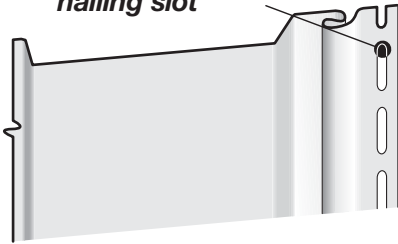

ring-shanked nails
and washers for
attaching foam 1 x 3 furring

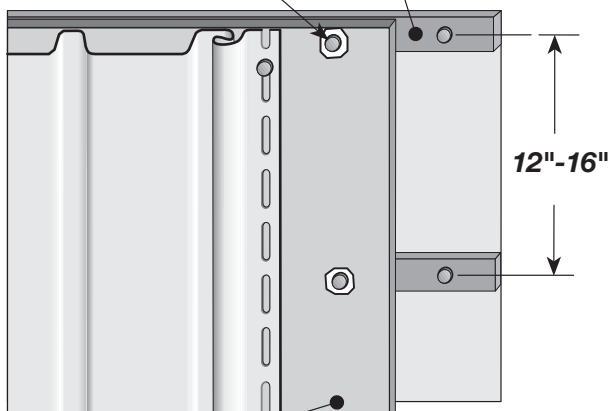

1/2" foam sheathing

always position
topmost nail in
topmost full nail
slot with vertical
applications

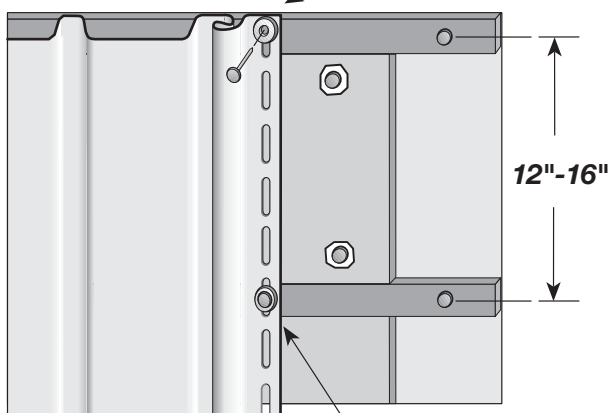

even with washers,
center nail in slots

Preparing Wall Surfaces

For the most part, the wall preparation instructions given for horizontal siding also apply to vertical siding. The key requirement, of course, is that you start with a **smooth, level and rigid substrate** (plywood, wood composite, rigid foam or fiber sheathing).

NOTE: Never install vinyl siding over open furring strips or studs. Always check with your local building code official.

With vertical siding, however, you may have to complete an extra step to provide solid nailing points along the vertical edge of the siding panel. The need for this added step depends on the type of substrate used and the nature of the construction project.

With new construction or remodeling using plywood or wood composite, there are no additional steps. You can nail into plywood and wood composite substrates at any point as long as you do not exceed 16" on center.

In new construction, using rigid foam or fiber sheathing, you must install solid wood nailer strips horizontally to studs **before** applying sheathing. Use 1 x 3 wood furring positioned 12" - 16" on center. **In high wind regions, including Texas, space the furring strips 12" on center. Check your local building codes.**

When remodeling over existing wood siding, you must apply rigid foam or fiber sheathing, shimming if necessary to create a level surface.

When remodeling over brick, block, stucco or irregular wall surfaces, apply furring strips **horizontally** to create a level surface, then apply rigid foam or fiber sheathing. See "Tips for applying wood furring" on page 22 and "Applying over stucco" on page 23. When reviewing illustrations for those sections, remember that furring strips must be applied horizontally with vertical siding. See page 24 for nailing instructions.

NOTE: When using Beaded T2" panel in a vertical application, nailing MUST be 8" to 12" o.c.

Marking a base line

The procedure is virtually the same as that described earlier. However, instead of snapping a chalk line 2-1/4" above the low point, snap it **1" above the low point.**

NOTE: Washers can be used for increased performance in high wind areas. See page 23 for horizontal illustration.

illustration
1a

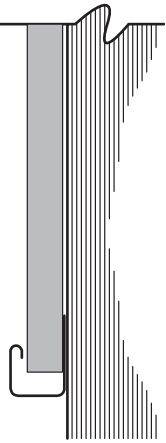

illustration
1b

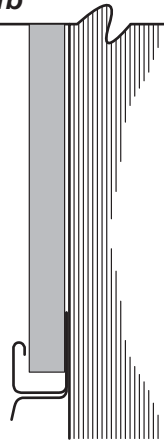
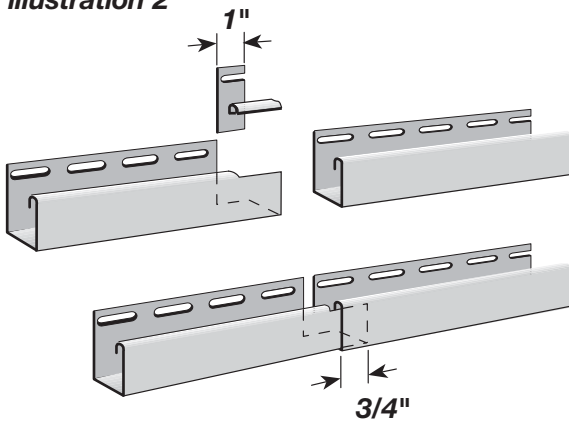

illustration 2



Installing Cornerposts

Install outside and inside cornerposts using dimensions and procedures described earlier.

NOTE: Unlike the preparation for horizontal siding, do not install a starter strip for vertical siding.

Installing Top and Bottom J-channel

Apply J-channel along the top and bottom of the walls to receive the siding panels.

Install the bottom J-channel (illustration 1a). Overlap J-channels 3/4". To do this, cut out a 1" section of the nailing flange and face return (see illustration 2).

NOTE: If you prefer to use drip flashing with the J-channel along the bottom of the wall, fabricate the lengths you'll need from aluminum coil stock of a color to match the siding (see illustration 1b).

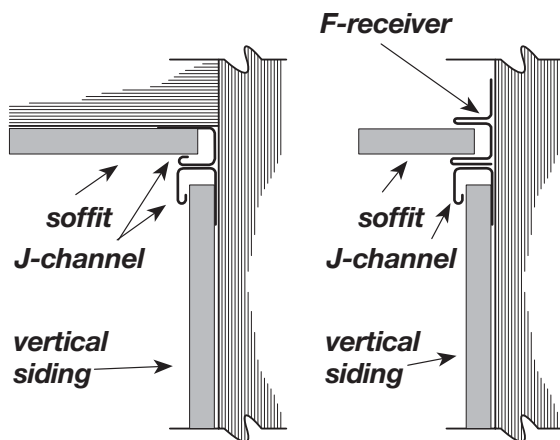

Install inverted J-channel along the top of the wall, under the eave. Here again, leave a 1/4" gap between J-channel and cornerposts. Overlap J-channels 3/4" to allow for expansion. When positioning the upper J-channel, be sure to allow for expansion of the siding panel. In most cases, position the J-channel at a point equal to the length of the panel plus 5/8" (1/4" for upper expansion and 3/8" for lower expansion).

NOTE: If you're going to install soffit, you may want to install the receiving channels for the soffit at this point.

The illustrations show alternative approaches for installing siding and soffit receiving channels.

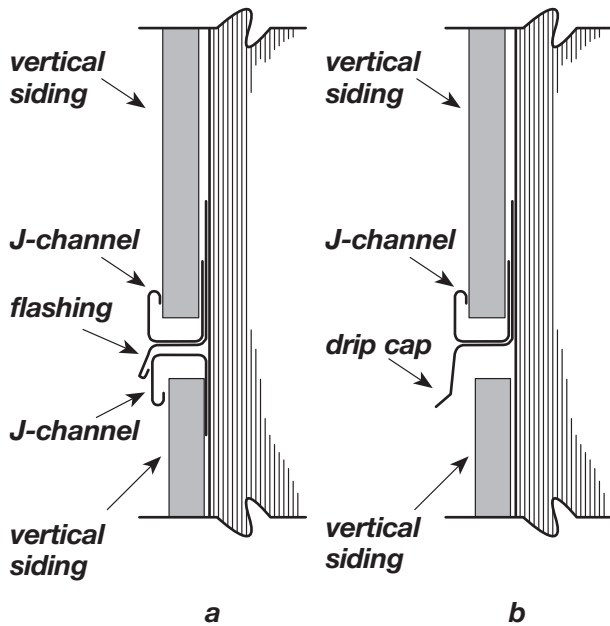

If a wall requires more than one course of siding, you can proceed in one of three ways:

Use two lengths of J-channel, back-to-back, at the joint between the two courses (illustration a).

Use a combination of one length of J-channel and one length of drip cap (illustration b).

Use a double channel lineal and flashing where required.

If using J-channel

Snap a chalk line parallel to the bottom J-channel, at a height equal to the length of the lower panel plus an allowance for expansion. For example, if the lower panel is 144" long and you're adding 1/2" for expansion (because the temperature is above 40° F), you strike a line 144-1/2" from the bottom J-channel. Nail inverted J-channels along this line to receive panels from below. Leave a 1/4" gap between J-channel and cornerposts. Overlap J-channels 3/4".

Prepare for the second course by applying head flashing above the just-installed J-channel. Then nail J-channel over the flashing to receive the upper panel.

NOTE: Some installers prefer to use formed aluminum flashing in place of vinyl drip cap as the receiving channel for the lower panel. This is also an acceptable approach.

Installing J-channel at Gable Ends

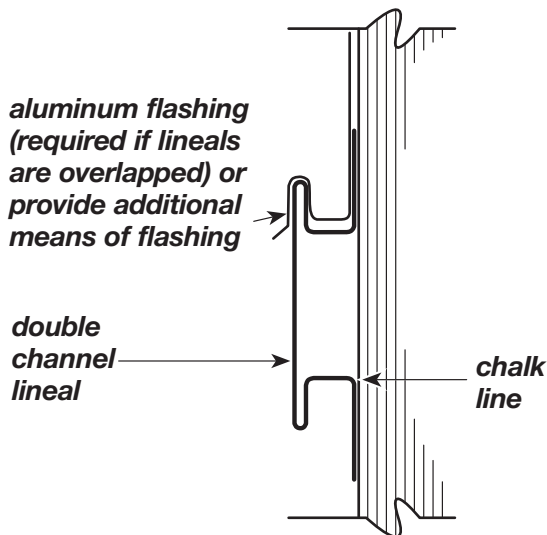

Follow the procedure described earlier under the section "Preparation for Horizontal Siding" beginning on page 21.

If using double channel lineal: Measure the length of the lower panel, then add an allowance for expansion. Snap a chalk line parallel to the bottom J-channel, at a height equal to your measurement. Position the lineal so the interior peak of the lower channel runs along the chalk line. Nail. Leave a 1/4" gap between lineal and cornerposts.

Where required, overlap lineals 1". Whenever lineals are overlapped, you must insert flashing into the upper channel, or provide additional means of flashing. Nail in place.

Installing Window and Door Trim

Follow the instructions described earlier under the section "Preparation for Horizontal Siding" beginning on page 21.

Plan the panel layout

Correctly installed vertical siding should have a balanced appearance. This means that if you were to draw a vertical line down the center point of a wall, you'd have an equal number of panels to the right and left. If you had to trim panels to fit, the end-most panels would be of identical width.

To create this pleasing appearance, divide the space to be covered by a partial panel over both ends of a wall. For example, if a wall required 25 full panels plus 10", you would rip cut two 5" lengths of panel to create the end pieces.

Important!

In a vertical siding installation, most of the expansion is downward. So instead of allowing equal space for expansion at both ends of a vertical panel, leave more space at the lower end: allow for 1/3 of the total expansion at the top of a panel and 2/3 of the total expansion is at the bottom.

For example, if the total expansion equals 3/4" (3/8" + 3/8"), allow 1/4" at the top and 1/2" at the bottom.

NOTE: Always position top most nail at the top of the top most full nail slot (2a). Center remaining nails in the slots (2b).

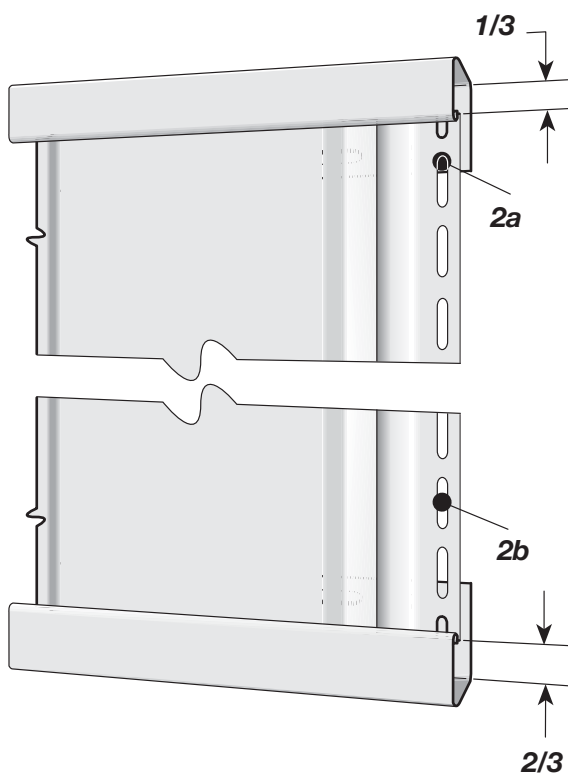

Installing Wall Panels

Cut the first of the partial panels (if partial panels are necessary). Mark the cut line by measuring from the nail hem edge. Rip cut the panel. Do not cut off the nail hem. Use a snap lock punch to create locking tabs along the cut edge. Space the tabs 6" apart.

Before installing this partial panel into the outside cornerpost, provide additional support at cut edge (to compensate for the locking channel that was trimmed off).

To do this, insert furring into the channel of the outside cornerpost and nail to substrate. After furring, insert a length of undersill trim into cornerpost and nail to furring. Finally, slide the cut edge of the panel into the undersill trim, making sure to engage the snap locks (see illustration).

Using a level, make certain this panel is plumb. Nail every 12". Follow the same nailing procedures described for horizontal siding.

Install the next panel. Lock the panel into the preceding panel, then nail every 12". Continue with succeeding panels.

When necessary, cut panels to fit around doors and windows. When marking the cut, remember to allow for expansion.

The method used to install panels around doors and windows is determined by the need to cut a panel and the position of that cut.

If a cut was made next to a remaining v-groove, insert the panel into the J-channel.

If a cut removes the support provided by a v-groove, use the procedure described above to provide support for the trimmed edge.

To finish the first course of a wall, cut the final panel to size and install in outside cornerpost, using method described above.

NOTE: *The cutting and supporting procedure described above is also used when fitting panels into inside cornerposts.*

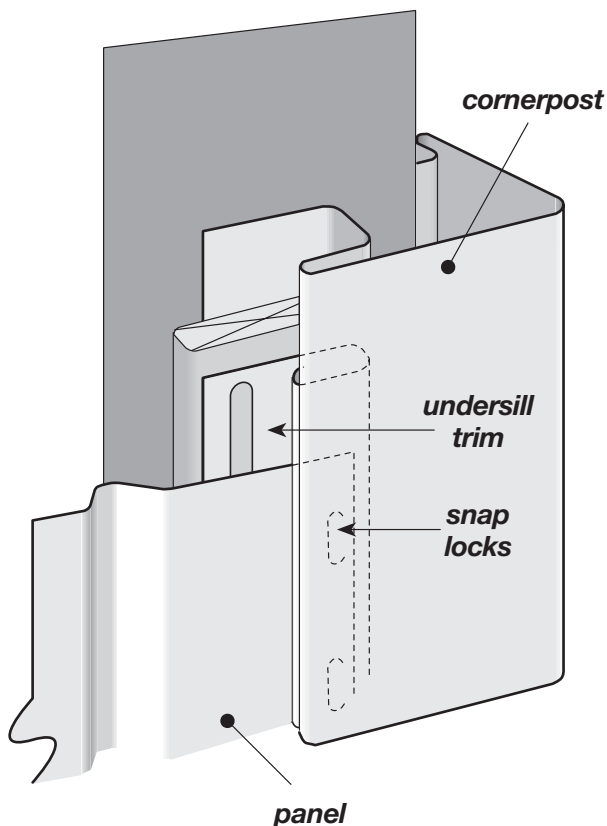

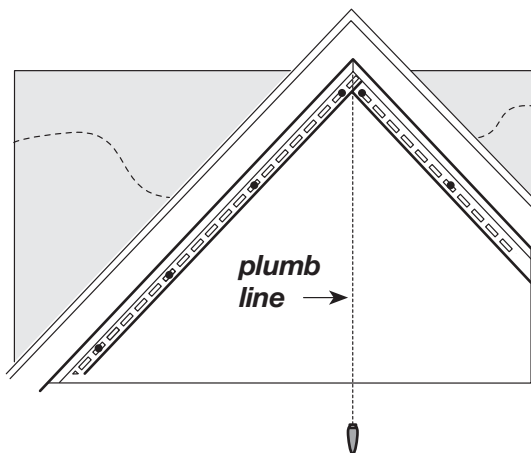

Installing Gable End Panels

When installing vertical siding on a gable end wall, you should try to create a balanced appearance.

There are two ways to do this:

You can start from the center of the wall and work toward the sides. Begin by finding the center point of the wall (beneath the peak) and draw a plumb line. Nail two lengths of J-channel, back to back, along this line. Be sure to flash underneath the J-channel to help prevent water damage due to water between the J-channels. Cut the upper end of the first panel to the proper height and slope. Remember to allow for expansion.

NOTE: *To guide the cutting of the upper end of the panel, make a pattern duplicating the gable slope. (See page 61.)*

Insert the panel into the J-channel along the gable slope. Use a level to make certain the panel is plumb. Nail every 12". Continue cutting and installing panels. Then repeat the procedure on the remaining half of the gable end.

If you want to work from one end of the wall to the other, begin by centering a panel under the center of the peak. Mark the position of the panel on the wall, then measure the distance from the left (or right) cornerpost to mark for the left (or right) edge of the center panel.

If you need a partial panel, cut it and install at the cornerpost, following the procedure described on page 69. Cut the upper end of the panels to proper height and slope, following the procedure described above. Remember to allow for expansion.

SECTION 7 – Porch Ceilings, Soffit, Fascia

Requirements for Proper Soffit Ventilation

Proper attic ventilation is important for any home. The 2003 International Building Code (IBC) Section 1203 Ventilation furnishes a basic guide for determining proper ventilation for any home. The information provided here may under certain circumstances not result in enough ventilation. Therefore, the calculation provided should be used as a guide only.

The IBC guideline requires that any attic or space between top floor, ceiling and roof must be ventilated. It requires one square foot of ventilation area for every 150 square feet of attic space.

If a vapor retarder of less than one perm has been installed on the warm side of the ceiling or if at least 50% of the required ventilating area has already been provided by gable and vents or ridge vents, you need add only one-half of the ventilation area that would otherwise be required. The requirement would then be one square foot of ventilation area for every 300 sq. ft. of attic space.

How to Determine Soffit Ventilation

1. Determine local code requirement for total attic ventilation.

1:150 requires 1 sq. ft. of ventilation for every 150 sq. ft. of attic space.

1:300 requires 1 sq. ft. of ventilation for every 300 sq. ft. of attic space, if a vapor barrier having a transmission rate not exceeding 1 perm is installed on the warm side of the ceiling.

2. Determine total area of attic (sq. ft.) to be ventilated.

40 ft. x 30 ft. = 1,200 sq. ft.

3. Total free area of ventilation required for attic.

1,200 sq. ft. / 150 = 8.0 sq. ft.

4. Convert square feet into square inches (sq. in.).

8.0 sq. ft. x 144 = 1,152 sq. in.

5. Location of vents.

50% at ridge, roof vent or gable vent = 1,152 x .50 = 576 sq. in.

50% at soffit / eave = 1,152 x .50 = **576 sq. in.**

6. Total soffit ventilation area required.

Area of soffit available for ventilation:

80 lineal ft. x 2 ft soffit depth = 160 sq. ft.

Ventilation area required per sq. ft. of soffit = 576 sq. in.

/160 sq. ft. = **3.6 sq. in /sq. ft.**

7. Soffit product selection.

Compare soffit ventilation area required to manufacturer's soffit product literature.

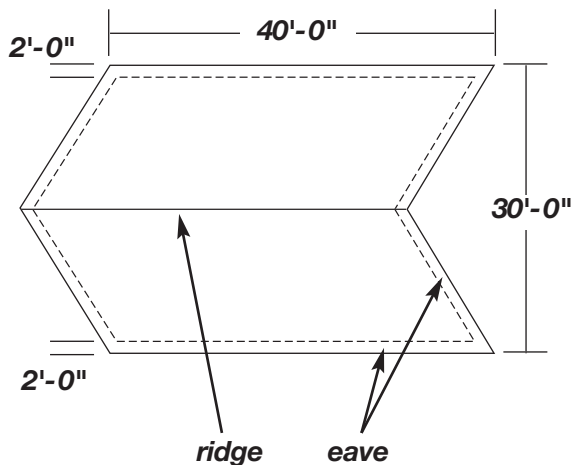

Porch Ceilings

The procedures used to install a porch ceiling are in many ways similar to those used to install soffit. These procedures vary slightly, depending on whether you're working on new construction or a remodeling project.

New Construction Projects

Begin by installing receiving channels on all four sides of the porch. If you are using F-channel, nail to existing walls. If you are using J-channels, you will have to install a nailing base.

If you plan to use light blocks to attach external light fixtures, install them to adequate backing.

Plan the layout of the ceiling panels to achieve an even balance or to align with adjacent work. If the ceiling panels will run parallel to the ceiling joists, you will have to install additional 1 x 3 wood furring nailing strips. Install these nailing strips perpendicular to the ceiling joists, placing a strip every 12" to 16".

Invert J-channels and nail them to underside of wood strips along the perimeter of the ceiling area.

NOTE: If you're using Beaded T2" panel as soffit, nail both the channel and the soffit every 8" - 12" to create added support.

Install the first panel into the channels at one end of the porch. Be sure to leave room for expansion. Nail every 12" to 16", positioning nails in the centers of slots. Do not nail tightly. Install remaining panels. When cutting the last panel of the first course, be sure to allow room for expansion.

For areas where more than one panel length is needed, use a double channel lineal.

If necessary, rip cut the final panel and use a snap lock punch to create tabs every 8" to 10" along the cut edge. Attach utility trim and insert panel into the receiving channel.

NOTE: For best results, ensure you have adequate ventilation.

Remodeling Projects

Check to be sure the existing ceiling can serve as a solid nailing base. If the existing ceiling is solid, remove all existing moldings and fixtures from ceiling and begin by nailing inverted J-channels along the perimeter of the ceiling area.

If you plan to use light blocks to attach external light fixtures, install them to adequate backing.

Plan the layout of the ceiling panels to achieve an even balance or to align with adjacent work.

Use the existing ceiling as a nailing base for the panels. Install the first panel into the channels at one end of the porch. Be sure to leave room for expansion. Nail every 12" to 16", positioning nails in the centers of slots. Do not nail tightly. Install remaining panels. When cutting the last panel of the first course, be sure to allow room for expansion.

For areas where more than one panel length is needed, use a double channel lineal.

If necessary, rip cut the final panel and use a snap lock punch to create tabs every 8" to 10" along the cut edge. Attach utility trim and insert panel into the receiving channel.

If the existing ceiling is not solid, install nailing strips to provide a secure nailing base, then install J-channels. You will have to install additional nailing strips if your ceiling panels are to run parallel to the ceiling joists.

If the ceiling panels will run parallel to the ceiling joists, you will have to install additional 1 x 3 wood furring nailing strips. Install these nailing strips perpendicular to the ceiling joists, placing a strip every 12" to 16".

Invert J-channels and nail them to underside of wood strips along the perimeter of the ceiling area.

Install panels as explained above.

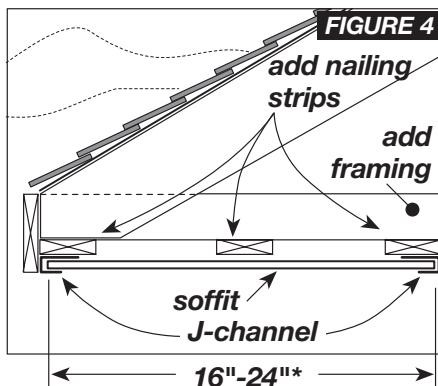
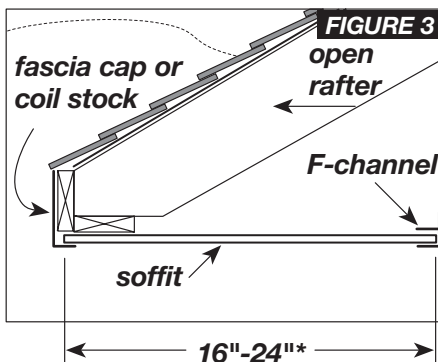
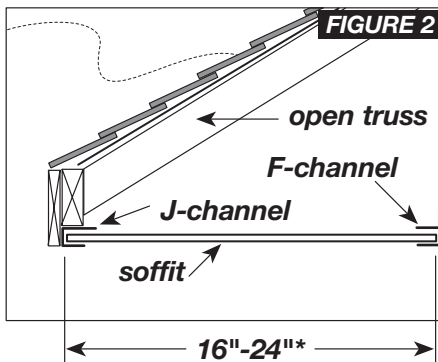
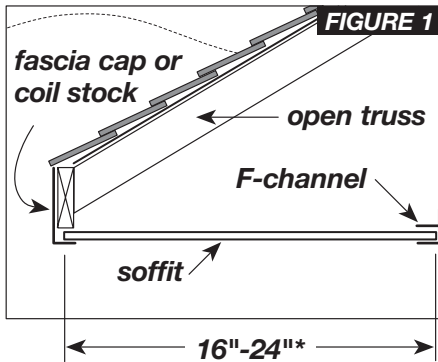

* To determine the maximum permissible span, consult individual product specifications and local building codes.

Soffit

You can use solid vinyl panels or perforated vinyl panels for soffit installations. Perforated panels provide ventilation, which helps to reduce heat buildup in the summer and ice dams in the winter. In buildings with roof ridge vents, you should install ventilated soffit. Check local building codes to determine the amount of ventilation required. In high windload areas, you should also check local building codes to determine if the application methods that are required differ from those described below.

The procedure used to install soffit depends on the construction of the eaves:

- **Open eaves**—eaves with exposed rafters or trusses—are typical of new construction. You will also have to use open eave installation procedures if you have to remove damaged soffit at a remodeling project.
- **Enclosed eaves**—eaves with soffit in place—are typical of remodeling projects.

Installation over Open Eaves

The first step in installing soffit is to install the proper receiving channels. You have several options for receiving channels. You can use accessories such as F-channel or J-channel, or you can make channels using coil stock. The best approach is to select a method that works most effectively with the construction techniques used to create the eave. Examine figures 1-4 and find the one that most closely resembles the construction methods used on your particular project.

If no F-channel is available, J-channel can be modified to create F-channel. Simply cut slots in the nail flange area where it would be nailed to the wall. After cutting the nail flange, bend the flange back and nail to the wall. When installing Beaded T2" panels, use 3/8" H-bar or 3/8" J-channel.

Installing Receiving Channels

Install the receiving channels following the details shown in figures 1-4. Nail the channels every 16", positioning the nail in the center of the slot. Do not nail tightly. If you're using Beaded T2" panel as soffit, nail both the channel and the soffit every 8"-12" to create added support.

If the eave span is greater than 16", you will have to install nailing strips (as shown in figure 4) and install the receiving channels on the nailing strips.

If the soffit will turn a corner, cut and install the channel so there is 1/4" for expansion at each of the adjoining walls.

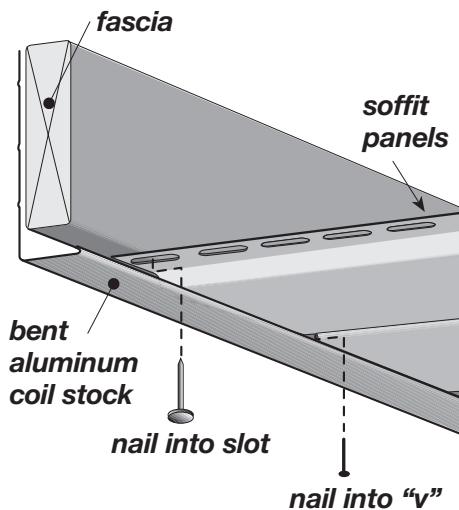

Installing Soffit

Measure from the wall to the fascia board. Then subtract 1/2" to allow for expansion. Mark this dimension on a soffit panel and cross cut the panel using a power circular saw with a reversed fine-tooth blade. Cut one or two panels at a time, carefully advancing the saw through the vinyl.

Insert the panel into the channel on the wall, then into the channel at the fascia board. You may have to flex the panel slightly to insert it into the second channel. Make certain the panel is perpendicular to the wall, then nail. Depending on the installation method you're using, you'll nail either to a nailing strip or to the fascia board.

If you're nailing to the fascia board, use small-headed nails. Drive the nail through the nail flange and "V" groove. This is one of the rare instances when face nailing is permissible. Once a soffit panel is face-nailed, it will expand only in one direction—in this case, toward the receiving channel. Be sure to leave space for the full expansion allowance in the receiving channel.

If you're using a nailing strip (as in figure 4), do not nail tightly—allow movement for expansion.

Continue installing the panels by locking and nailing the soffit in place. Make certain soffit panels are fully locked along their entire length.

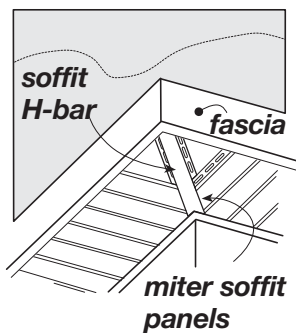

Turning a Corner

To turn a corner, measure from the channel at the wall corner to the channel at the corner of the fascia board. Subtract 1/4" for expansion. If necessary, install nailing strips to provide backing for the lineal. Cut and install soffit double channel lineal or H-bar. Miter the corner soffit panels and install as described above.

Completing the Installation

To complete the installation, apply utility trim and fasten aluminum fascia cap or formed aluminum coil stock with painted trim nails. If you must face nail fascia, drill holes for the trim nails to allow for expansion and to reduce denting of the aluminum.

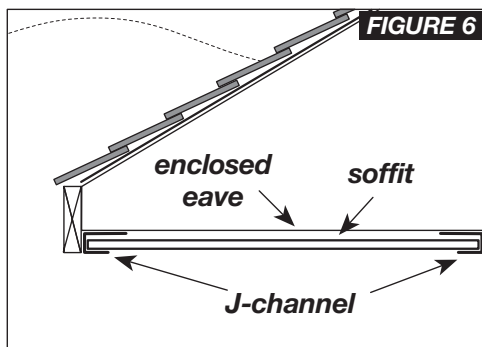
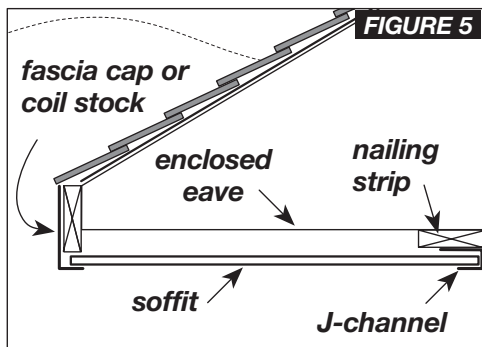

Installation over Enclosed Eaves

If the existing soffit is rotted or damaged, it's best to remove it completely before installing vinyl soffit. Then use the instructions for open eaves.

If you're installing perforated soffit panels and the existing soffit doesn't have openings for ventilation, cut an adequate number of openings. Then complete the installation as described for open eaves.

The procedure used to install soffit over an enclosed eave is almost identical to that used for an open eave. The major difference is the installation of the J-channel. Determine the method you'll use to install soffit at the fascia board (see figures 5 and 6). When installing J-channel at either the wall or the fascia board, nail the J-channel every 12"-16".

Turning a Corner

If the soffit is to turn a corner, cut and install J-channel so there is 1/4" for expansion at each of the adjoining walls and adjoining fascia boards. Miter the corner soffit panels and install as described above.

InvisiVent Soffit

Installation over open eaves

In most situations, InvisiVent™ Super Ventilated Soffit should be installed like our standard soffit products. However, when InvisiVent is installed over open eaves, follow these installation techniques.

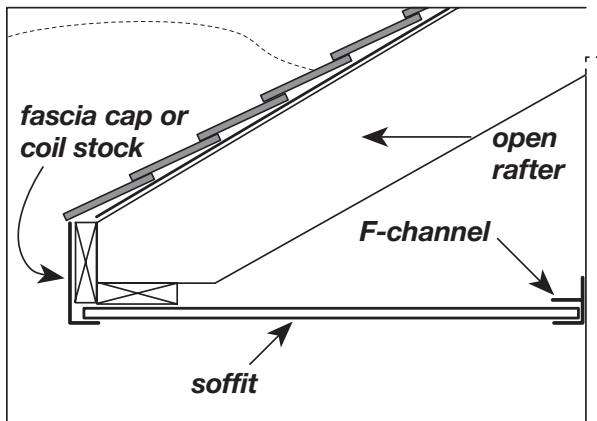

Install receiving channels

There are two ways to install receiving channels for soffit. The best approach is to select a method that works most effectively with the construction techniques used to create the eave. Examine the illustrations, and find the one that most closely resembles the construction methods on your particular project.

Use either 3/4" J-channel or 3/4" F-channel, or you can make receiving channels using coil stock.

Install the receiving channels following the details shown in the illustrations.

Nail the channels every 12" to 16", positioning the nail in the center of the slot. Do not nail tightly.

NOTE: If you are concerned about excessive insect infiltration, cover the opening with corrosion-resistant mesh or other screening before installing the soffit.

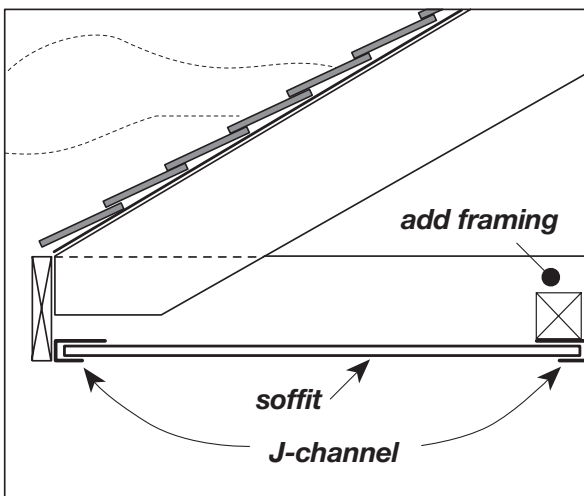

Install soffit

Nail the soffit every 16" or 24", depending upon local building codes and stud spacing. InvisiVent will span up to 24" without additional nailing strips.

Installation over existing soffit

When installing InvisiVent Soffit over an existing solid wood soffit, you must cut openings into the existing soffit to provide adequate airflow through the InvisiVent Soffit. The goal is to have at least 9 square inches of net free air per lineal foot of soffit. Removing a center portion of the existing soffit will provide the desired airflow.

Using a saw, cut along the length of the existing soffit. Leave 2" to 3" from both the wall and the fascia so that you will have enough wood surface to securely fasten the InvisiVent.

Remove the center portion of the existing soffit.

Install the InvisiVent Soffit as described above.

Fascia

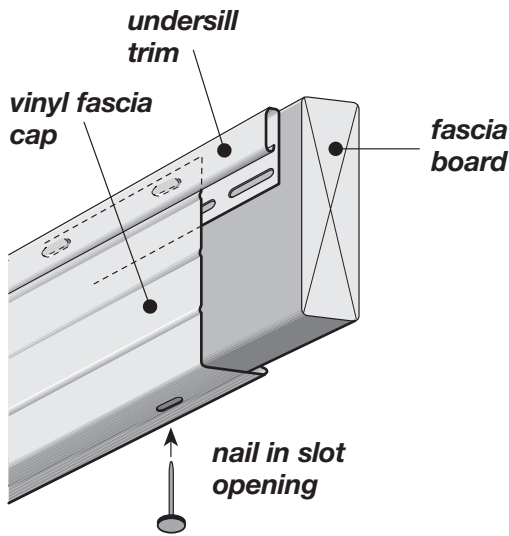

The wooden fascia board that encloses the front of an eave also needs protection from the weather. To provide this protection, you can install vinyl or aluminum fascia panels.

There are two procedures for installing vinyl fascia panels—one for installations that include soffit, one for installations without soffit.

Installations without soffit

Nail undersill trim in place along the top of the fascia board.

Before installing the panel, create tabs along the top edge using a snap lock punch.

Hook the bottom of the fascia panel under the bottom of the fascia board. Push the top edge into the undersill trim, as shown, or behind drip edge.

Secure the panel to the bottom of the fascia board with white trim nails. Fasten at nail slot openings only (see illustration).

Do not face nail fascia panel.

When overlapping fascia panels, first cut a notch in the underlying panel. The notch should be 1/8" deep by 1-1/2" long. Slip the notched panel into the adjacent panel (see illustration).

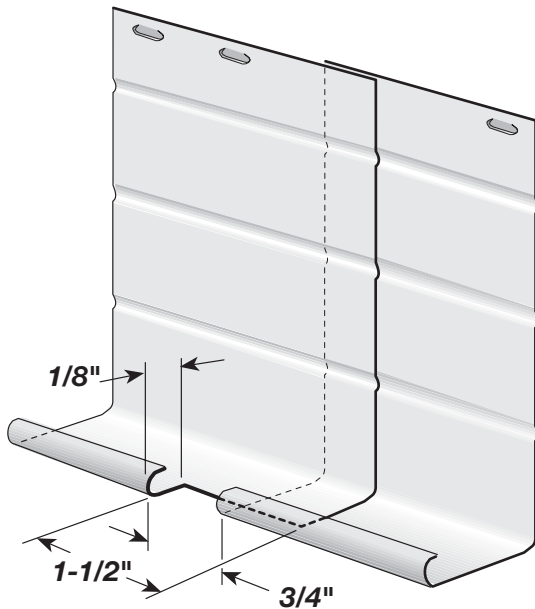

To turn a corner, you must first fabricate a corner piece. Cut a length of fascia panel so it extends 6" beyond the corner. Mark a vertical line to indicate the position of the corner. Then cut a 90 degree V-notch centered on the vertical line. Score along the vertical line and fold. Finally, create tabs along upper edge with snap lock punch. The tabs must be raised on the outside face of the panel (shown on the next page).

Fit the panel on the corner, making sure to overlap the preceding panel.

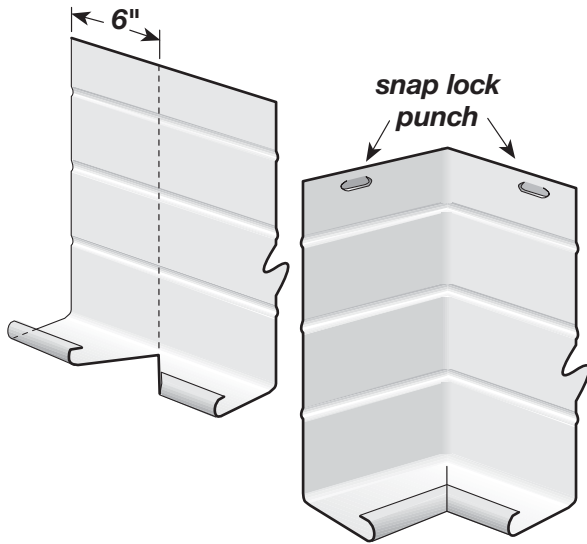

For installations that include soffit

Nail undersill trim in place along the top of the fascia board. Then nail F-channel along the bottom outside surface of the fascia board (shown).

The fascia panel will have to be rip cut to fit over the fascia board and F-channel. To determine the width of the panel, measure from slot in undersill trim to bottom of F-channel. Deduct 1/4" and cut (shown).

Use a snap lock punch to create tabs 1/8" below cut edge. Punch tabs every 6", with tab raised on outside face of panel.

Install the panel by hooking the bottom of the fascia panel under the F-channel and pushing the top into the undersill trim (shown).

Continue to install the fascia as described on page 78.

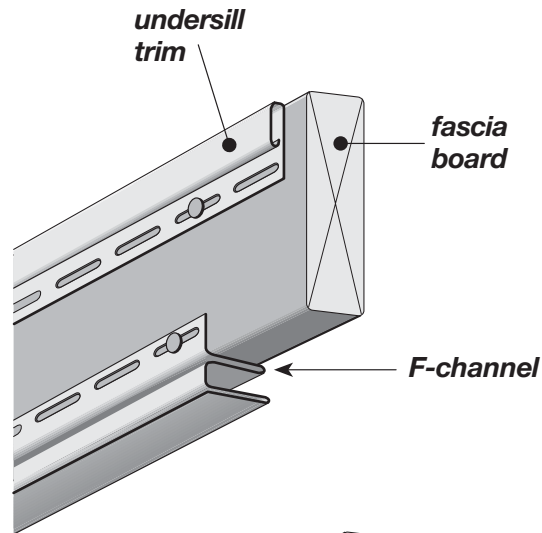

Aluminum fascia

The techniques used to install aluminum fascia panels are similar to those used with vinyl— with three exceptions. There is no special undersill trim to use with aluminum fascia. Aluminum fascia is made without nail slots, so you have to pay attention to proper nailing techniques. And corners are handled differently.

Install drip edge, gutter or all-purpose trim along the top of the fascia board to receive the top edge of the fascia panel.

Slip the fascia panel in place, then nail the underside of the panel. Nail every 24", keeping nails lined up with soffit V-grooves.

For best appearance, first drill a slightly oversized hole. Nail with painted trim nails, using a light touch.

At outside corners, bend a 1" flange at a 90 degree angle so it turns the corner. Then cut the overlapping fascia at a 45 degree angle. Position panels and nail.

NOTE: *If you need a piece of nonstandard size fascia, use a portable brake to form it from aluminum trim sheet. Install and nail using the same techniques used with standard fascia panels.*

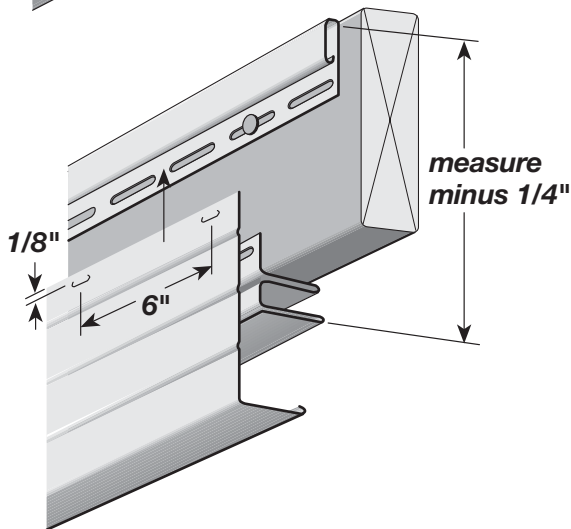

SECTION 8 – Installing Specific Wolverine Products

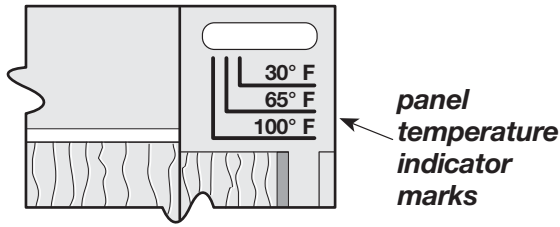

use these marks on installed panels for quick alignment of second course – use temperature indicators for final panel adjustments

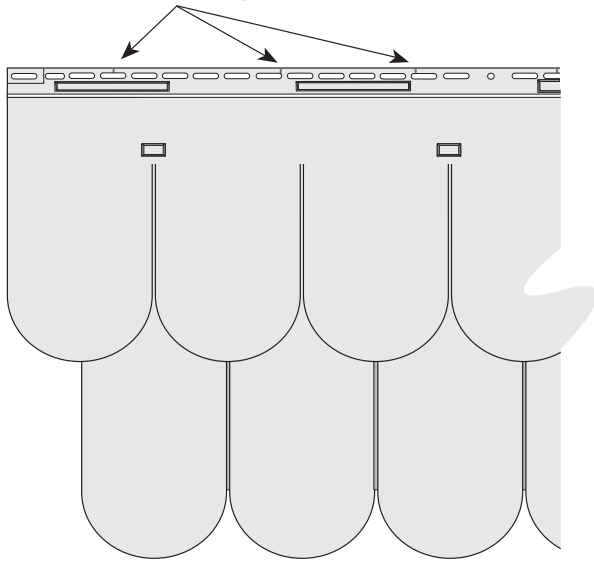

Restoration Shapes Half-Rounds Installation

Important

This product is not designed for roof application. It is designed solely for installation on vertical surfaces.

Panels must be installed with nails over a solid substrate with nail holding strength such as plywood, oriented strand board, or existing wood siding (minimum 7/16" thick). This product cannot be installed with staples.

NOTE: *Each panel must be nailed through the round hole in the center of the nail hem to control the direction of normal expansion and contraction. If you are installing a partial panel and the center nail hole has been cut off, drill a nail hole in the center of the nail hem of the cut panel and nail through it.*

Panel Spacing at Different Temperatures

As with any plastic siding, Restoration Shapes siding expands and contracts with changes in temperature. For this reason, it is important that you space the panels according to the panel temperature at the time of installation. Failure to provide the proper spacing according to these temperature ranges may result in gaps that are too large or too small, thereby creating the potential for side lock tabs disengaging, panel distortion, or buckling. Spacing of panels previously installed at a different temperature does not require adjustment.

Each panel has indicator lines that serve as guides for proper spacing between the panels. The indicator lines are on the upper left-hand corner. Before you install Half-Rounds, **make sure the panels are acclimated to the ambient temperature**. As the ambient temperature changes during the day, it may be necessary to adjust the panel spacing to reflect the change in the panel temperature.

Space the panels according to the panel temperature at the time of installation.

Panel Temperature	Temperature Indicator Lines
30° to 40°	Set to 30 line
41° to 55°	Set halfway between 30 and 65 lines
56° to 75°	Set to 65 line
76° to 90°	Set halfway between 65 and 100 lines
91° to 100°	Set to 100 line

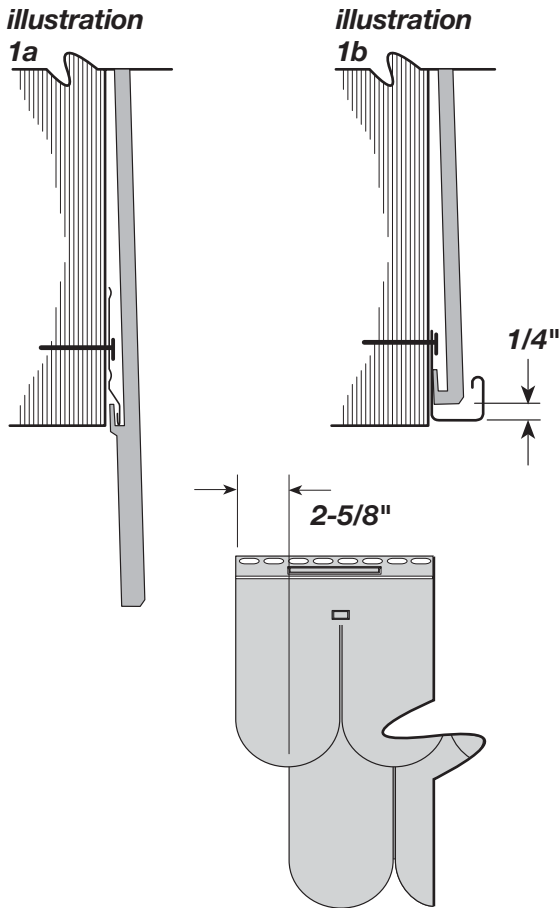

First course

Strike a level line around the house and install Restoration Shapes Starter (see illustration 1a). An alternative method of starting Half-Rounds is to use J-channel in place of starter strip, to receive the bottom edge of the panel (see illustration 1b). To use this method, the rounded portion of the panel must be removed below the locking leg to create a continuous straight edge.

NOTE: When using a J-channel as a starter, leave 1/4" between the siding panel and pocket.

Remove 2-5/8" from the left side of the upper panel course, leaving a 90° left side edge.

Starting on the left side of the wall, hook the bottom edge of the panel into the starter strip and slide the panel into the cornerpost or receiving channel. Leave 1/4" space between the panel and the inside wall of the cornerpost for expansion.

Fasten the panel to the wall by first nailing through the round center hole of the nailing hem at the top of the panel. Then fasten the rest of the panel by nailing through the centers of the remaining nail slots a maximum of every 8" to 16" on center. Provide 1/8" to 1/16" between the nail head and the panel to allow freedom of movement during normal expansion and contraction. Failure to provide this space between nail head and panel will cause the panel to buckle. Do not put a nail into the far right slot until overlapping panel is positioned for installation.

Install next panel by using a dual motion of hooking into the starter strip and sliding over the previous panel. This will ensure a proper lap.

Position overlapping panel so that there is 1/8" to 1/4" between the panels, **depending on the panel temperature at time of installation.** The spacing may appear larger or smaller than the spaces between the shingles on the panel. This is normal and necessary in order to allow for expansion and contraction.

Nail in center of far left slot of overlapping panel.

Continue to install remaining panels of first course as described above.

always secure first using center pin hole

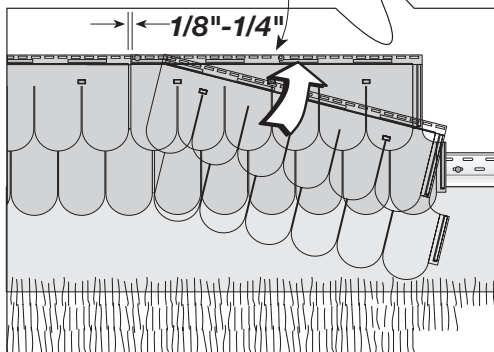

drill 3/16" diameter hole at midpoint of remaining panel

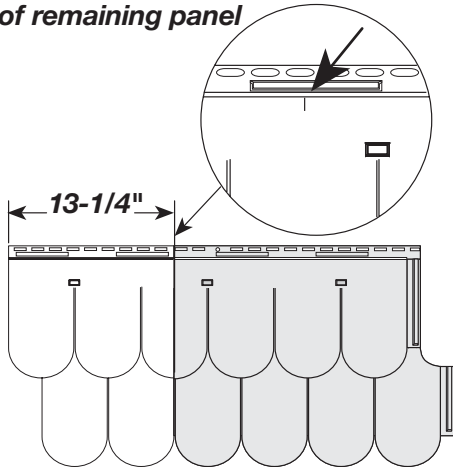

Second course

Remove 13-1/4" of the left side measured from the upper panel, cutting straight through the lower panel course. (Note the small mark on the face of the panel.) Drill a 3/16" hole in the center of the nail hem and nail the siding through this hole to control the direction of expansion and contraction.

NOTE: The 13-1/4" spacing provides the farthest separation of overlapping courses.

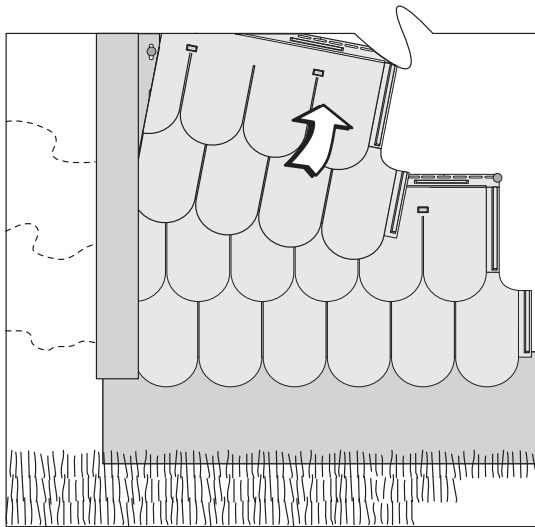

For easier application of complete panels, 1/4" vertical lines have been added to the top edge of the nail flange for quick initial alignment. Simply align the right edge of the upper panel with one of the vertical alignment marks on the lower course. However, always use the temperature indicator marks on the right side of the upper panels for final alignment.

Restoration Shapes Half-Rounds may also be installed by sliding the right panel up while ensuring the side lock tabs engage with the flange of the left panel. This method is useful when installing panels into cornerposts and J-channel around windows and doors.

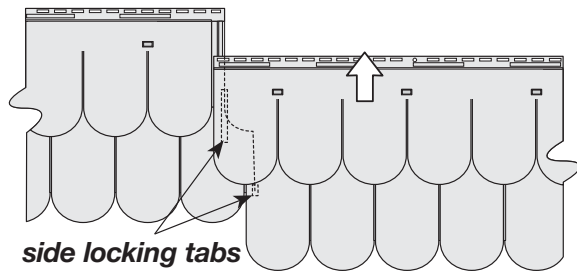

Continue to stagger panel courses, alternating each time to ensure a random shingle pattern up the wall.



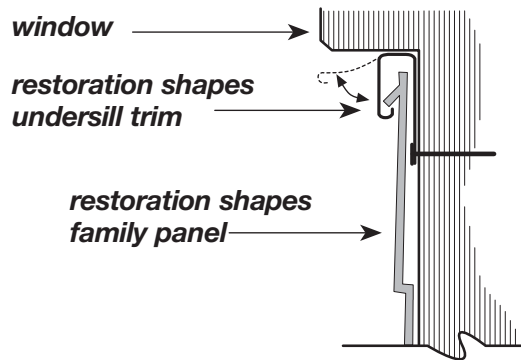

Installing under a window or opening

Install Restoration Shapes undersill trim. Cut the panel to fit under the window. Drill a 3/16" hole in the center of the nail hem. Using a snap lock punch, raise tab faces on the outside of the panel 1/4" from the trimmed edge, 6" apart. Lock the panel into the previous course, and center nail the siding through the 3/16" hole drilled earlier. (Center nailing controls the direction of the panel's expansion and contraction.) Lock the panel into place.

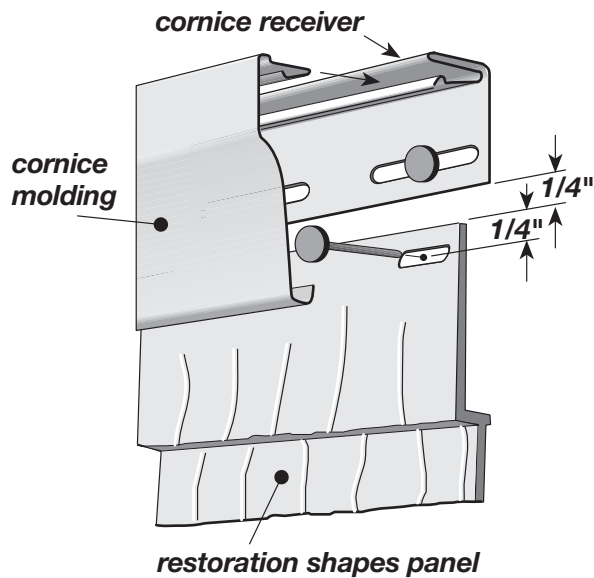

Installing over a window or opening

To install siding over a window, measure from the lock tab of the course below the window top to the top of the window. Add 3/4". Cut the panel to this dimension. This will allow the panel to be lowered down far enough to engage the locking tabs of the lower panel. After it is positioned into the locked position, the cut edge will still be 1/4" below the top of the J-channel.

Finishing the top course

To finish the top course of siding, attach cornice receiver to the top of the wall under the eave or soffit. Trim the top panel to within 1/4" of the cornice receiver. Using a nail slot punch, punch nail slots 1/4" from the trimmed edge, 16" apart. Nail off the top course, and snap the cornice molding into the cornice receiver.

An alternate method is to use J-channel and furring strips.

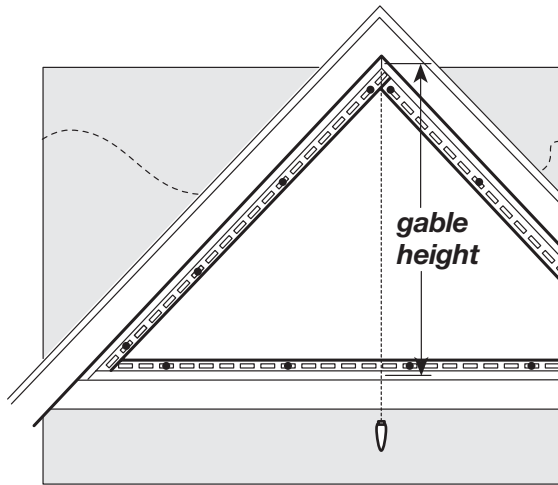

Half-Rounds in Gable Ends

NOTE: The following instructions focus on a gable installation. They also are geared towards an enclosed gable, started with a J-channel. Half-Rounds can also be started with starter strip. This is an example only!

Installing receiving channels

Frame the border area with 3/4" J-channel. Nail in place loosely. Miter joints accordingly.

NOTE: You also can use 3-1/2" or 5" lineals to frame gable ends and gable base. For instructions on cutting lineals for peaks, see "Gable Trim" on page 55.

Cut enough J-channel to span the base of the gable, then secure it in place.

NOTE: The instructions below show how to create a gable installation with a complete, centered Half-Round at the peak.

Making the starter course

Gable installations properly terminate with a single round at the peak. To create this effect, you usually have to adjust the height of the starter course.

To determine the height of the starter course, calculate the number of rows required to complete the gable.

Use the following formula:

Gable height (inches) ÷ 12.5 (face exposure) = courses required

NOTE: Gable height is measured from inside the horizontal receiving channel to the peak (allowing 1/4" at top and bottom for expansion).

For example, with a 68" gable height, the calculations would be $68 \div 12.5 = 5$ with a remainder of 0.44. This means you would need 5 full courses plus 0.44×12.5 (face exposure of panel) = 5.5" measured from the top edge of the gap on the upper course (illustrated). This is the visible height for your starter course. The visible height is the vertical dimension of the panel you'll see below the first full row of rounds.

Once you've determined the visible height of the starter course, mark this dimension on a Half-Rounds panel. Measure from the top of the gap on the upper course (illustrated). Draw a cutting line the entire length of panel.

Cut and use the top section, which contains the locks, as your starter course. Cut enough panels to span base of the gable.

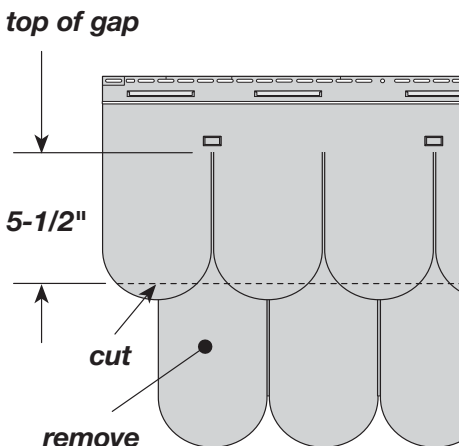
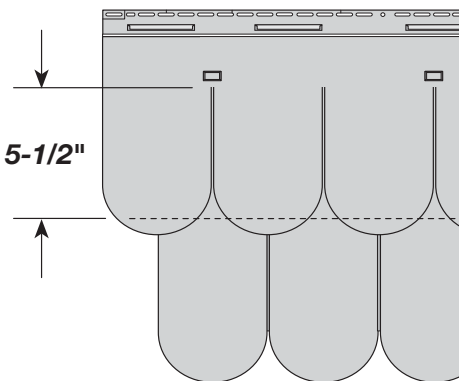

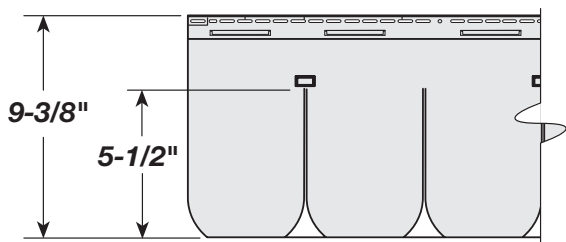

Hanging the starter course

To end up with a single “round” centered at the peak of the gable, you must properly locate the first starter panel.

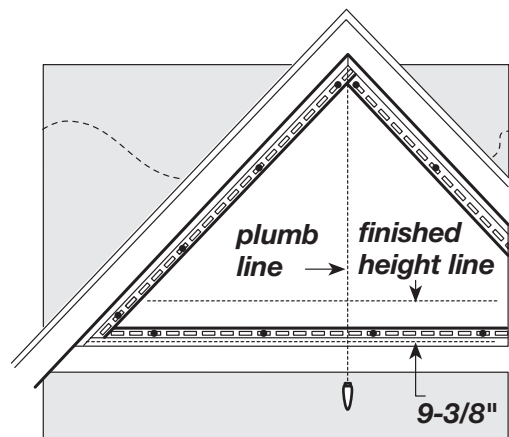

Begin by marking a vertical plumb line from the peak.

Then measure and mark the finished height line. In our example, using a starter course with a 5-1/2" visible height, the finished height is 9-3/8".

With your ruler inserted into the pocket of the lower J-channel, mark a line on the substrate equal to the finished height (remember to allow 1/4" for expansion). Repeat at several points along the gable base. Use these marks to strike a horizontal level line that will guide the nailing of the starter course.

The point where the plumb line and the horizontal level line intersect marks the starting point for hanging the first starter course panel (if the first starter panel intersects the plumb line).

Determine whether you will center a “scallop” or a “V” at the starting point. This decision is based on the number of courses required to complete the gable.

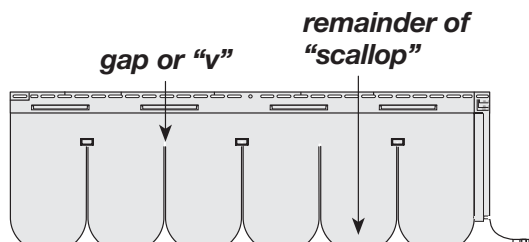

The rule of thumb is:

Center an upper scallop if the initial calculations had less than 0.5 courses remaining (0.44 in our example).

Center the gap or “V” of the upper course if more than 0.5 courses remained.

(In our example we require 5.44 courses, so we would center on a scallop.)

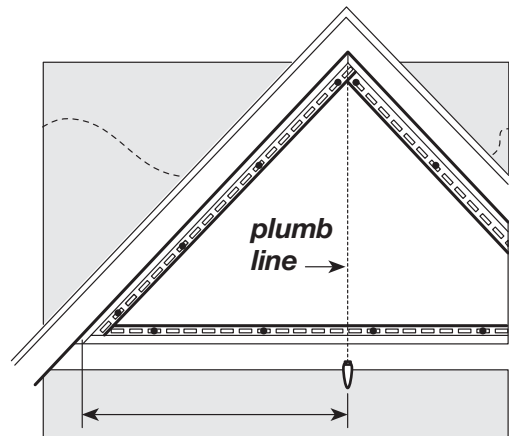

More than one panel will probably be required to reach the plumb line. Measure from the plumb line into the pocket receiving channel (leaving 1/4" for expansion) as illustrated at left.

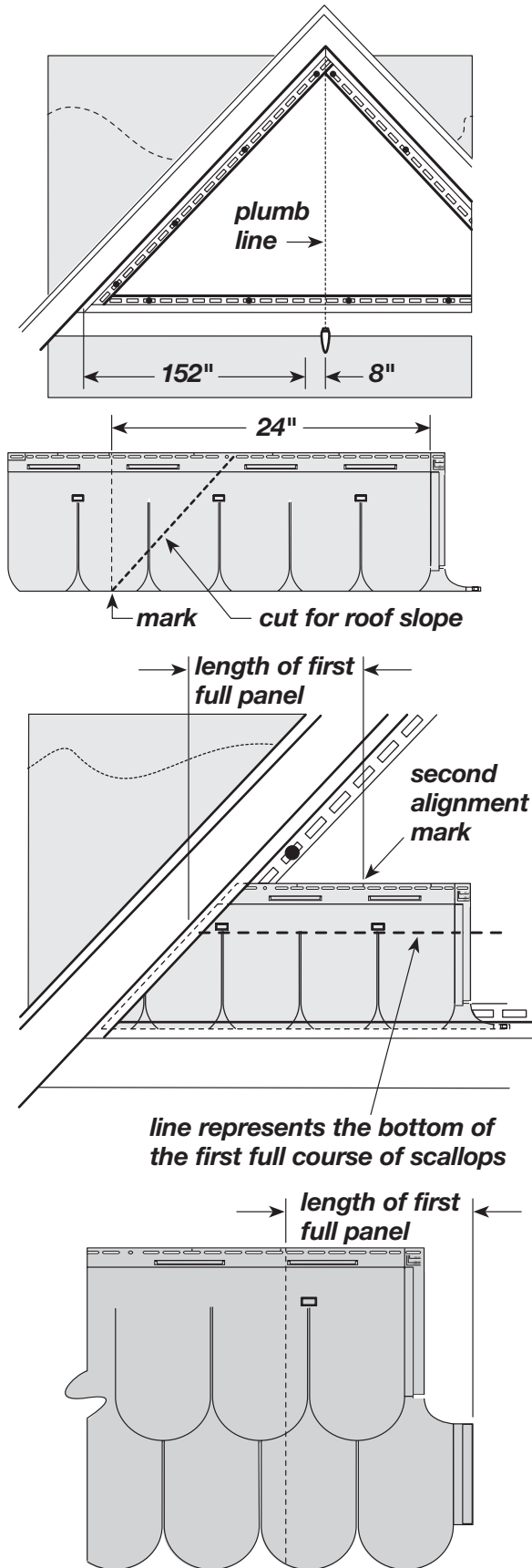

If you require an odd number of courses (i.e. five full courses plus starting course), subtract 8" from the distance from the plumb line to the left receiving pocket (remember to allow 1/4" for expansion).

If you require an even number of courses (i.e. 6 full courses plus starting course), subtract 18-1/2" from the dimension.

NOTE: The 8" and 18-1/2" dimensions ensure having a full centered scallop at the topmost part of the gable.

For example: If the measurement required to the plumb line (minus 8" for an odd number of full courses) is 152", then $152" \div 32" = 4$ full panels plus 0.75% of one panel or 24" measured from the edge of the texture on the right side (temperature indicator side).

Create a cutting guide as described earlier for gable applications and trim first panel (for this example) at 24". Continue to hang the remaining starter course strips, remembering to center nail first.

Installing first full panel

It is important to stagger the panels, as described in this section. The easiest way to determine the length of panel required is to measure from the alignment line on the nail flange of the starter panel to the edge of the roof slope (see illustration).

Using this measurement, drill a hole centered in the remaining nail flange as described earlier. Lock the first full exposure panel to the starter course after trimming for roof slope.

After locking panel in place, center pin the panel.

Lapping remaining panels

The remaining panels to be installed must be lapped in accordance with the current temperature.

Repeat this process for the entire course.

At the end of each course, trim panels to the gable angle. Be sure to allow for expansion at the J-channels.

Installing the last round

When you reach the peak, trim the last round to the desired height by removing the locks. Then face nail to the substrate, using a color-matched finishing nail.

Installing Restoration Shapes Half-Rounds on Non-vertical Walls

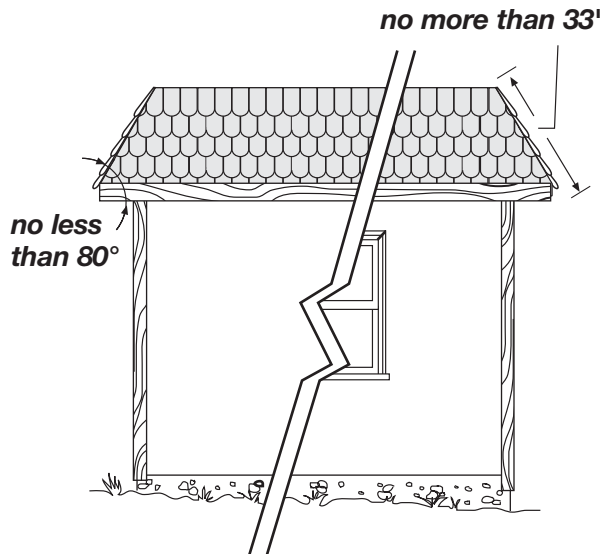

Half-Rounds must never be used as a roofing material. However, they can be used on non-vertical walls that meet the following conditions:

The non-vertical wall must not be greater than 10° off the vertical (no less than an 80° angle).

The top of the wall cannot be higher than 33' above ground level.

The non-vertical wall must not be a functional roof above occupied space. It must be decorative.

Before you install Half-Rounds panels on a non-vertical wall, install an underlayment of 15 lb. (minimum) felt or waterproofing shingle.

Cap the uppermost edge of the top siding course to prevent the water from getting behind the siding. Flash all accessories to shed water away from the substrate, just in case water gets behind the siding in these areas.

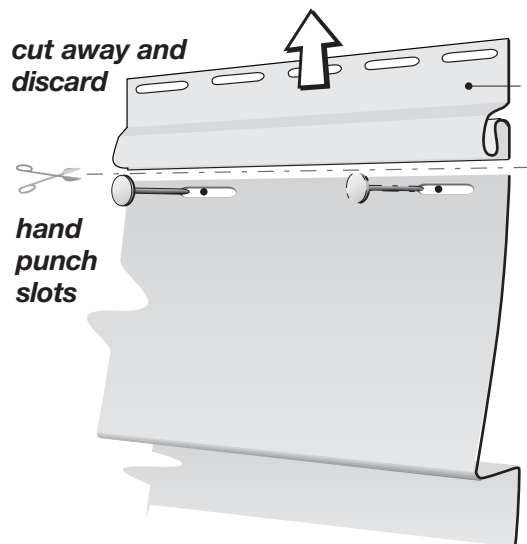

Starting Half-Rounds over Horizontal Siding

Cut away nail flange and discard.

Hand punch nail slots in panel face and secure panel.

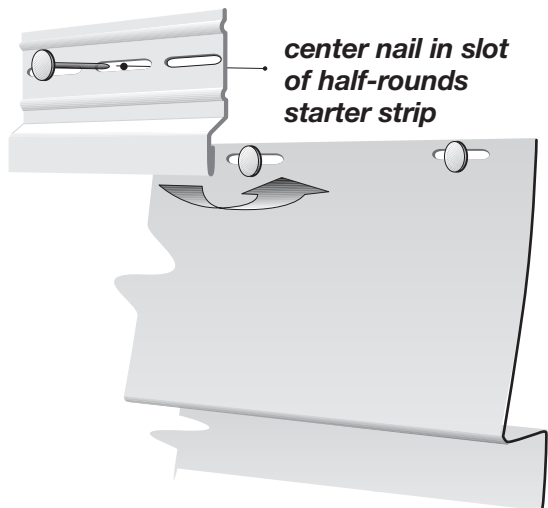

Secure Half-Rounds Starter after hand punching and securing siding piece.

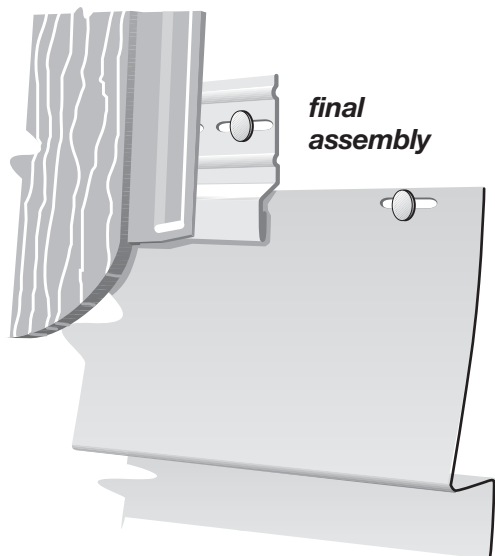

Lock Half-Rounds panels into the starter strip and secure.

Starting Half-Rounds with Lineals over Horizontal Siding

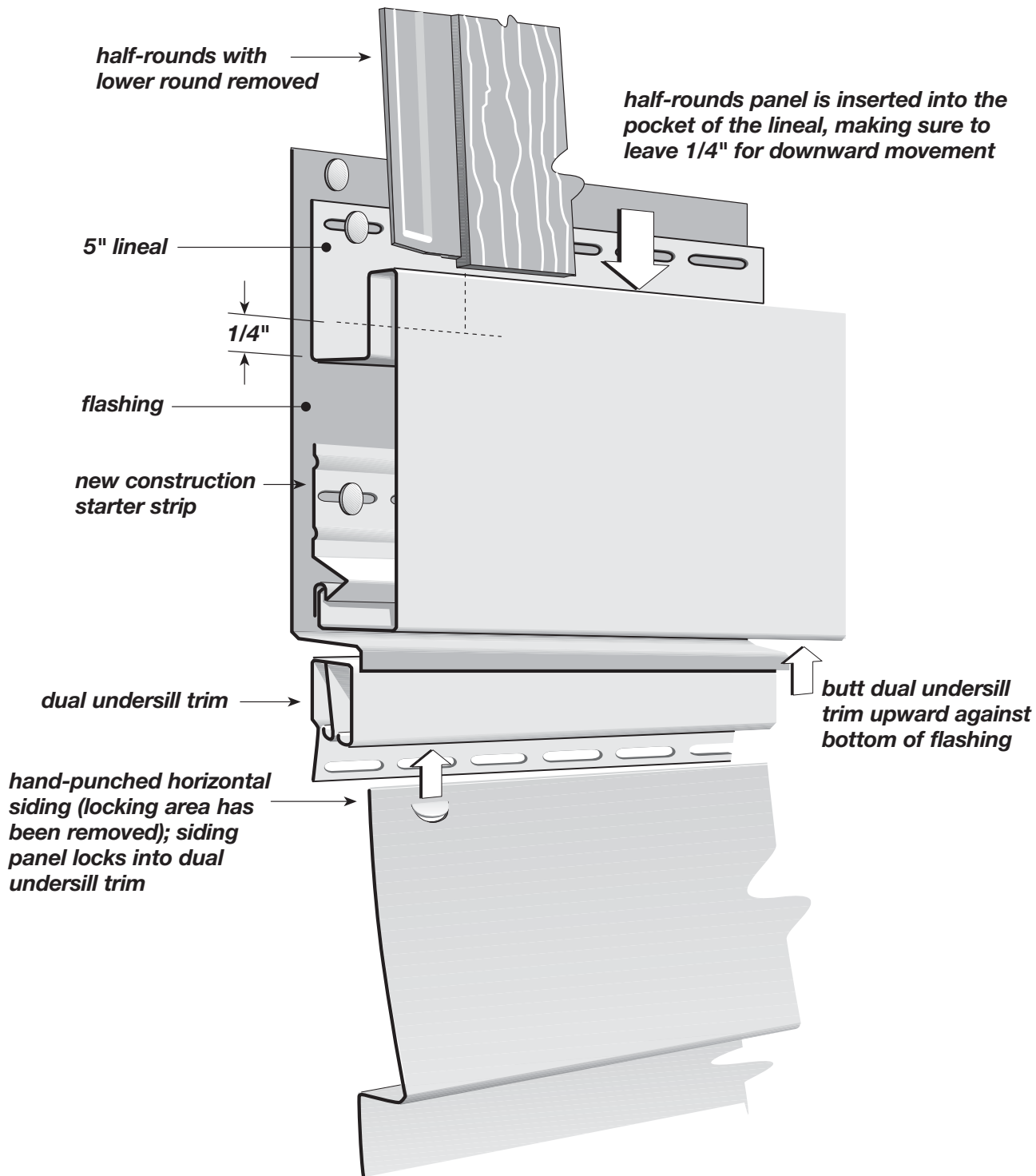

Application of Half-Rounds under Soffit

The amount of trimming required of a Half-Rounds panel determines the accessory piece required to receive it. See the descriptions below.

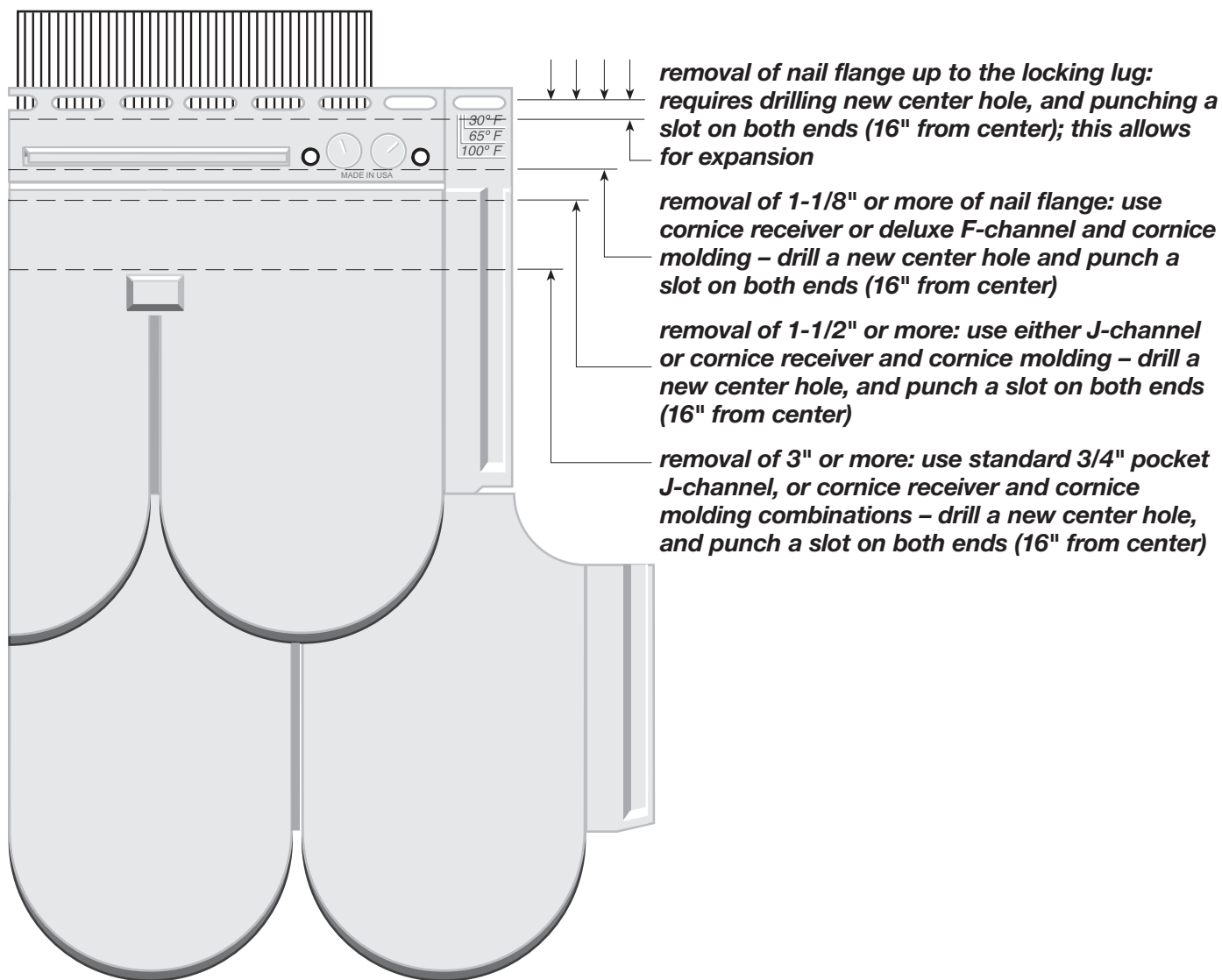

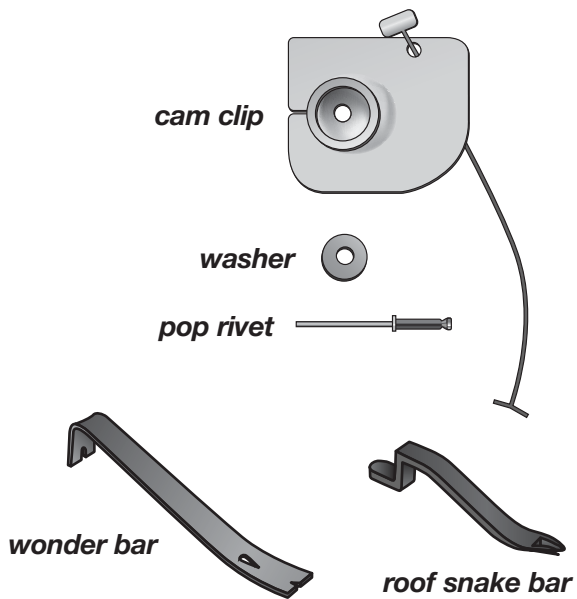

Replacing a Damaged Restoration Shapes Half-Rounds Panel with the Repair Kit (Option 1)

Included in kit: cam clips, washers and pop rivets.

Required tools: hammer, utility knife, chisel, pop rivet gun, and “wonder bar” or “roof snake bar”.

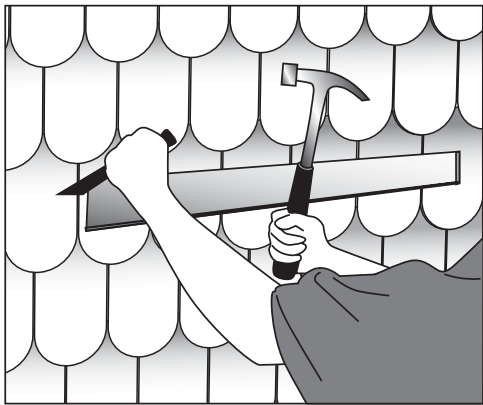

Removing the damaged panel

Cut a large rectangle out of the damaged panel. Cut or chisel through the sides of the panel and remove lower half.

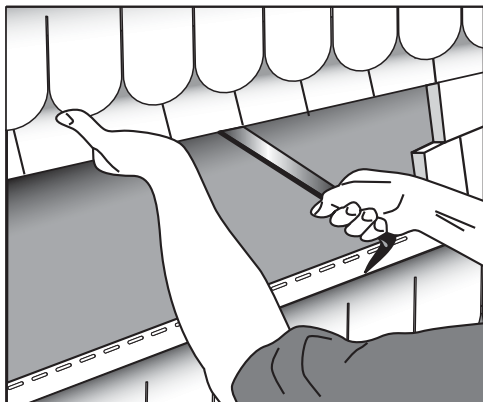

Pry nails out of the nail hem of the damaged panel.

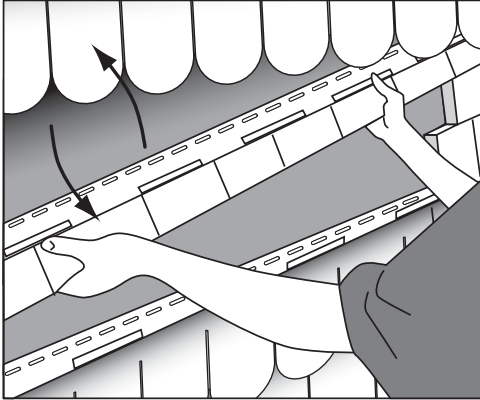

Push up on the panel to unlock and then pull down to remove the damaged panel.

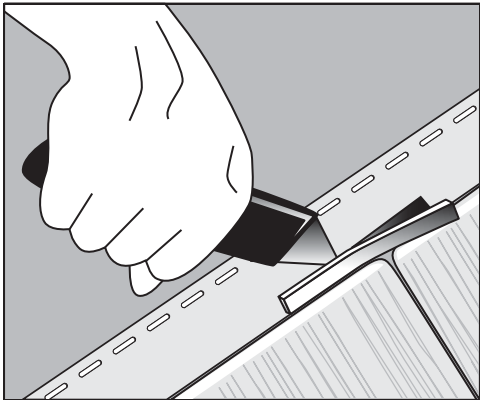

Preparing the new panel
Cut off all top locking tabs.



Flip panel over and cut 1/8" off the 3 side locking tabs.

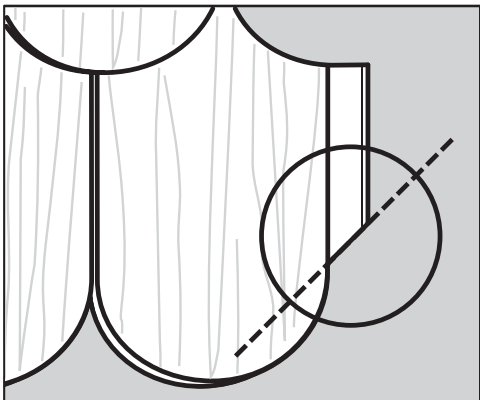

Notch the side locking tab on a 45° angle.

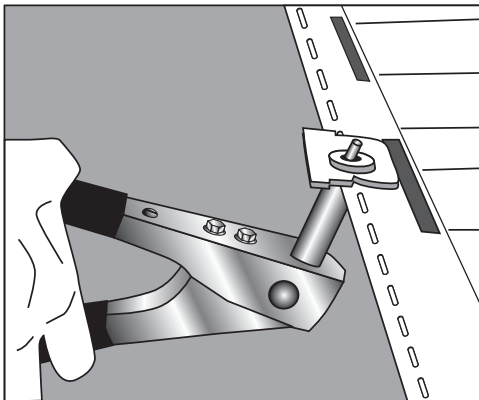

From the back, insert a pop rivet into a nail slot above one of the locking tabs. Then place a cam clip and a washer over the pop rivet. Squeeze the pop rivet gun to set the clip. Repeat over each locking tab area. Now you are ready to install the new panel.

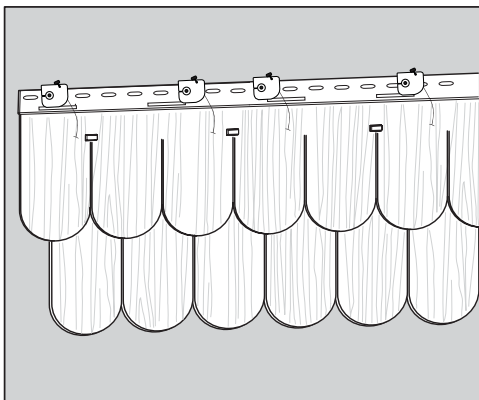

Install 4 cam clips in nail slot locations from left to right 3, 13, 18, 28.

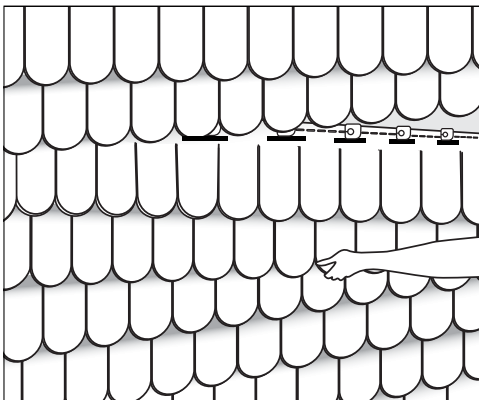

Installing the new panel

Slide the left side of the new panel into the side locking tabs. As you raise the new panel into position, make sure the bottom lip of the panel engages the locking tabs on the panel below. Also, be sure all the cam cords hang down and are visible.

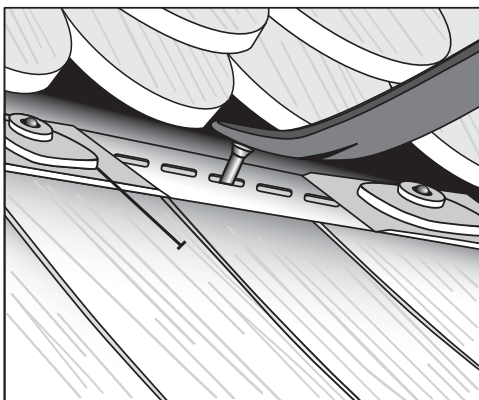

Lift up the panel above the new panel far enough to place the nails into the old nail holes.

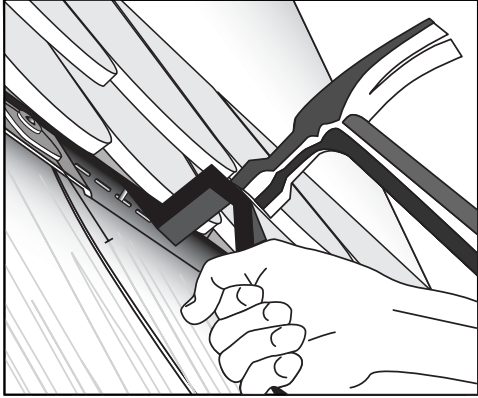

Using your Wonder Bar or roof snake bar, drive the nails in by placing the bar on the nail head and hitting the bar with a hammer.

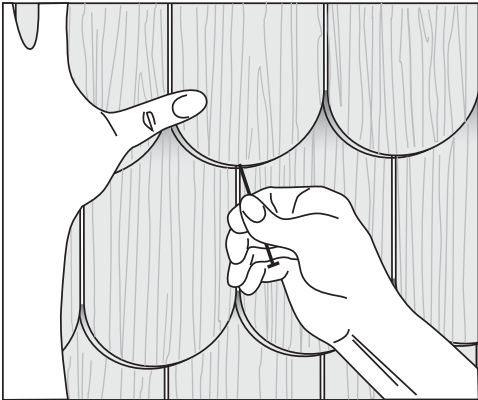

While applying pressure to the top panel, pull down on the cam cords. **Make sure each cam clip engages the lip of the panel above it.** Keep pulling down on the cam cords until they break off.

Replacing a Damaged Half-Rounds Panel (Option 2)

Required tools: hammer, wood chisel and hacksaw or utility knife.

Use a wood chisel to remove the lock tabs on the top side of the damaged panel. Lock tabs can be located by using the chisel to slightly lift the panel locked into the upper portion of the damaged panel.

After locating the lock tabs, place the bevel of the chisel down against the face of the damaged panel; use a hammer and the chisel to knock off the lock tabs of the damaged panel. Then pull the nails on the damaged panel and pull the panel down and remove.

On the replacement panel, use a hacksaw or utility knife to cut the lock tabs to half their original length. Slide the replacement panel back into the position of the removed damaged panel.

Use the hammer handle to put pressure against the bottom butt of the replacement panel to force pressure upward enough that the replacement panel will engage with the panel above.

Drill a nail hole in the center of the top portion of the replacement panel, then use a colored trim nail to control the direction of expansion of the replacement.

NOTE: While this method provides an aesthetically acceptable replacement, it does not actually secure the panel to the wall. The only way to secure a replacement panel with nails is to remove the siding from the top of the wall down until the damaged panel can be removed.



locate lock tab with chisel tip and remove

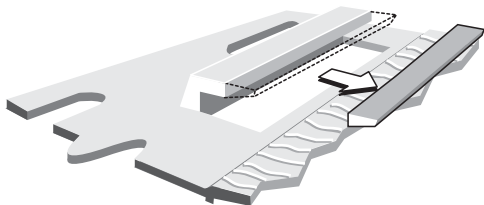
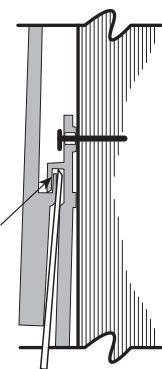

half-rounds (upper course)

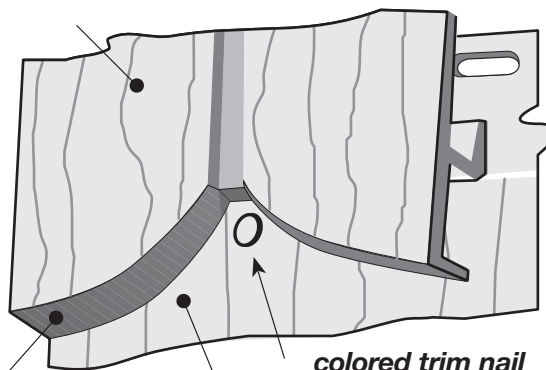

butt leg of upper half-rounds panel

colored trim nail
half-rounds (lower course)

Random Hand-Split Shakes

Overview

The installation of Random Hand-Split Shake is unique in that the lap joint is hidden in the ribs between the shake patterns. Positioning the laps in the rib area requires that special installation procedures be followed to maintain product performance and aesthetics.

Factory Laps: All lap joints are cut at a predetermined point on the panel during the manufacturing process. All laps must be factory cut. There should be NO field cutting of laps.

Install from right to left: Panels must be installed from right to left. The left panel will overlap the right panel.

Center Pinning: Each panel contains a short vertical slot, perpendicular to the nail slots which indicates the center of the panel. To maintain an aesthetically correct rib width at the lap joint for warm and cold temperatures, it is necessary to limit panel movement. This is accomplished by center pinning all panels. Center pinning will prevent the rib width at the lap joint from becoming too wide or too narrow.

Install the siding according to one of the following methods, depending on whether the substrate is or is not fully nailable.

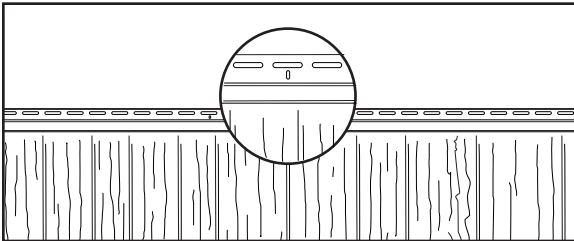

Installation procedure for fully nailable substrate

Lock the right side panel into place on the starter strip. Allow room for expansion and contraction in all accessory pockets:

- 1/4" if temperature is above 40° F.
- 3/8" if temperature is below 40° F.

Locate the short, vertical slot on the nail hem and center pin the panel in this location using one of the following options:

- a. Install a nail on both ends of the same nail slot.
- b. Pin the panel by fastening directly through the nail hem.
- c. Drill a 3/16" diameter hole through the nail hem and substrate, and place a single fastener through this newly drilled hole.

Install nails in the center of the remaining slots, 16" apart. Leave adequate room between the fastener head and the nail flange for expansion and contraction (approximately 1/16" to 1/8").

IMPORTANT: DO NOT HARD NAIL THESE FASTENERS.

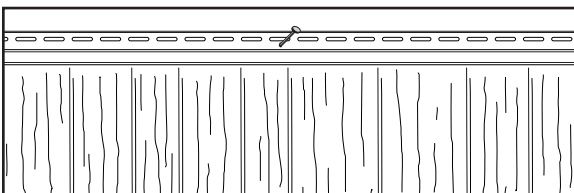
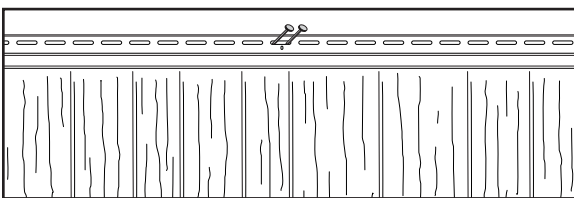

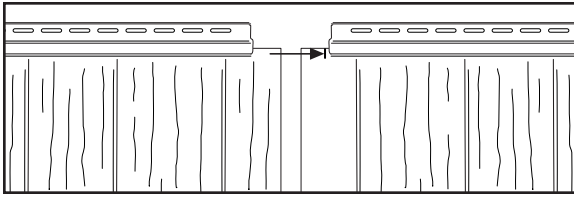

Install the next panel to the left of the installed panel. Lap this panel over the installed panel, positioning the right edge of the panel to a vertical “temperature mark” located in the factory notch area (approximately 1" from the left, top edge) of the installed panel.

Fasten the panel according to the procedure described earlier.

Continue the first course of siding.

Start the next course of siding from the right side, repeating the steps above. Remember, offset the laps from course to course a minimum of two feet.

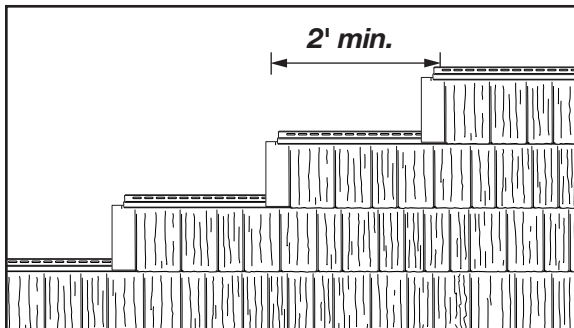

Installation procedure for a NON-fully nailable substrate

Lock the right side panel into place on the starter strip. Allow room for expansion and contraction in all accessory pockets:

- 1/4" if temperature is above 40° F.
- 3/8" if temperature is below 40° F.

Locate the short, vertical slot on the nail hem (which indicates the center of the panel). Locate the framing member (wall stud) nearest the center of the panel and “center pin” the panel into framing member using one of the following options:

- a. If a nail slot is located over the framing member, install a nail on both ends of the same nail slot.
- b. Pin the panel by fastening directly through the nail hem.
- c. Drill a 3/16" diameter hole through the nail hem and framing member, and place a single fastener through this newly drilled hole.

Install nails in the center of the remaining slots, 16" apart, secured into a framing member. Leave enough room between the fastener head and the nail flange for expansion and contraction (approximately 1/16" to 1/8").

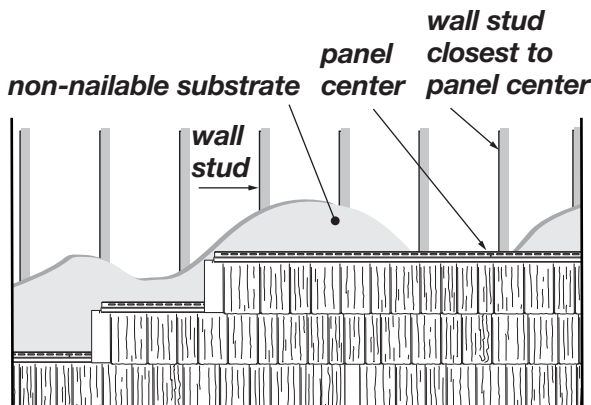

cut away view of wall construction

IMPORTANT: DO NOT HARD NAIL THESE FASTENERS.

Install the next panel to the left of the installed panel. Lap this panel over the installed panel, positioning the right edge of the panel to a vertical “temperature mark” located in the factory notch area (approximately 1" from the left, top edge) of the installed panel.

Fasten the panel according the procedure described earlier and continue the first course of siding.

Start the next course of siding from the right side, repeating the steps above. Remember, offset the laps from course to course a minimum of 2 feet.

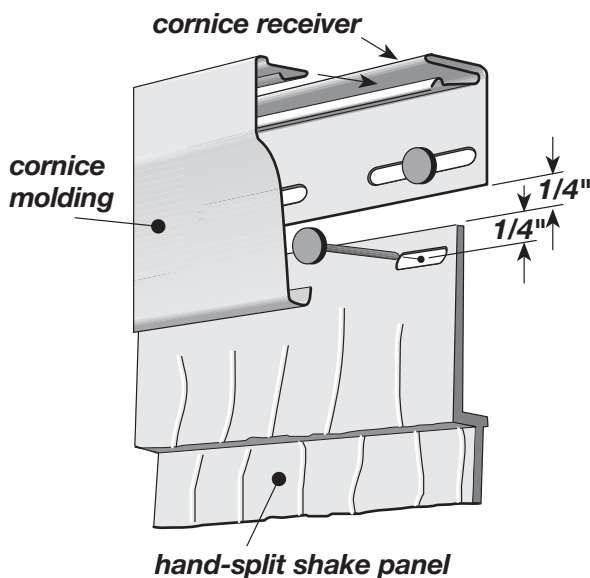

To finish the top course

Attach cornice receiver to the top of the wall under the eave or soffit. Trim top panel to within 1/4" of cornice receiver. With a nail slot punch, punch nail slots 16" apart, 1/4" from the panel's upper edge. Nail through the center of the holes for a loose fit between panel surface and nail heads.

Install the cornice molding by snapping it into the cornice receiver. To join two lengths of cornice molding, remove 1" from the snap-in portion of the cornice molding. Be careful not to remove material from the face that will show upon installing. Remove 1" from the return, which is located at the bottom of the cornice molding. Install into cornice receiver and overlap, allowing 1/4" for expansion. Be sure the laps are located away from the heavy traffic areas, when possible.

NOTE: An alternative method to finishing the top course with cornice molding and cornice receiver is to hide the nail heads with the soffit receiving channel or with the deluxe F-receiver and cornice molding.

It may be necessary to place a spacer behind the L-receiver before installing. Foam or some other material is adequate. The spacer must run the entire distance of the L-receiver. This will make the application more aesthetically pleasing by creating the proper clearance between the cornice molding and the channel pocket.

NOTE: Other than center pinning, installing from right to left, and lapping to a temperature mark, standard fastening procedures associated with vinyl siding are used.

Installing Millennium® Siding

Millennium siding, which features the NailTight™ Flexible Hem, attaches tight to the wall and floats from PermaFlex™ suspension cables.

The flexible nail hem is woven of tough synthetic fibers. It has red and black threads that form the “strike zone,” the maximum performance target for fastening panels to the wall.

Storing Panels

Millennium panels can be stored like vinyl siding. However, take care to ensure that the nail hem does not become folded or permanently creased. If the nail hem is creased, hand straighten it before fastening the panel to the wall.

Fasteners

Even though the NailTight Flexible Hem may be fastened firmly to the wall, the fastener requirements are similar to regular vinyl siding. Use only corrosion resistant aluminum or galvanized roofing nails or screws with a minimum 3/8" diameter.

Siding Nails and Screws

If a nail is used, the point and shank of the nail should target the black strand and stay within the red strands.

With steel studs, use noncorrosive, self tapping screws with at least 3/8" (9.5mm) diameter head and 1/8" (3mm) diameter shaft. The screws must be at least 1-1/8" long. You may need to install a washer to avoid spinning the fabric.

Staples

Installation with staples is similar to nails, except a **minimum** of one of the staple legs must be within the red strands. The staple should be corrosion-resistant, have legs long enough to penetrate 3/4" into the wood of the subwall, and have a 7/16" crown.

The angle of the staple is also important. A vertical position (ideal) up to a 45° angle ensures the maximum wind load resistance. Lesser angled or horizontal staples cause the load to be distributed over a smaller number of cables.

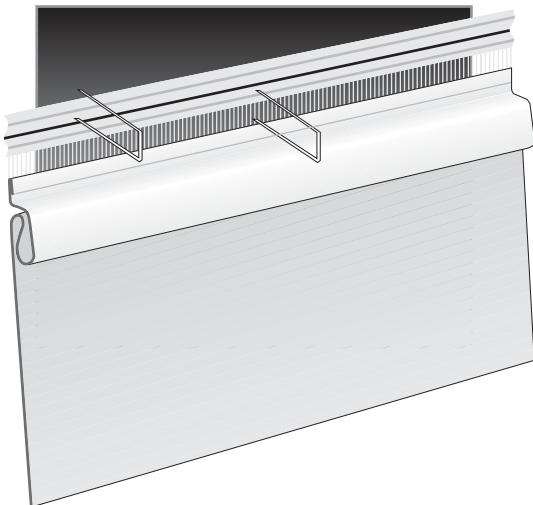
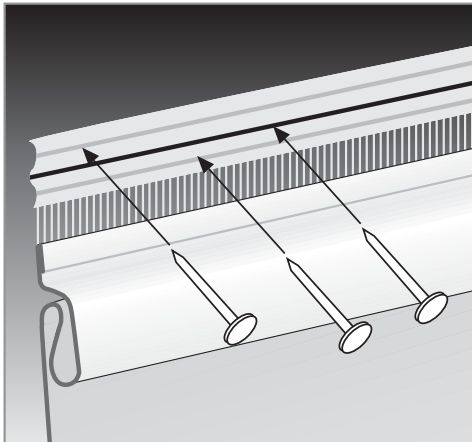

Staple Orientation



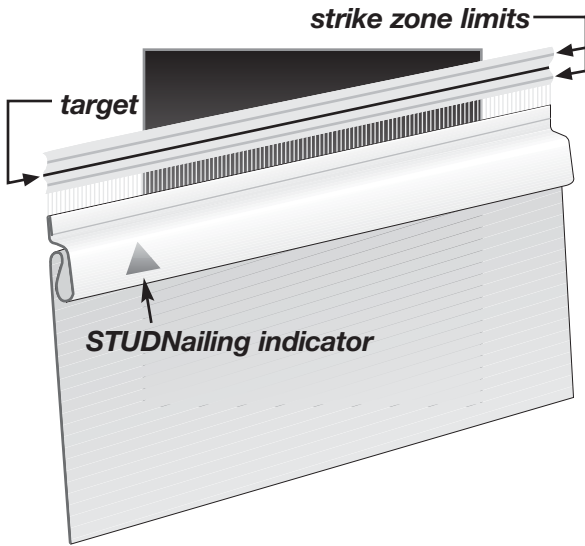

NOTE: Nails or staples *must not* be installed less than 16" on center.

Fastening

Millennium siding is different from other vinyl siding in that it is OK to drive the fastener up tight against the flexible hem. The PermaFlex cable system transmits the load to the panel and allows the panel to expand and contract with changes in temperature.

Fastener Location

Colored strands along the solid band of the flexible nail hem identify the fastener target zone. The black strand indicates the center of the target, while the red lines indicate the upper and lower ranges of the zone. These limits are important to ensure the panel has enough freedom to compensate for temperature-related panel movement.

16" STUDNailing™ Indicator

Nails or staples must not be installed closer than 16" o.c. To ensure proper nailing, STUDNailing™ Indicator arrows are printed at 16" intervals along the Millennium panel. Fastening the panel at these arrows will ensure consistent nailing.

Fastener Depth

With nails, staples or screws, it is important to not overdrive the fastener. The fastener should be driven flush with the substrate, not drawing the fabric into the substrate. This is important especially over foam substrates as excessive fastener penetration will draw the fabric in and limit its ability to compensate for panel movement. The fabric cannot be driven into the substrate more than 1/16".

Panel Lock

Millennium's Grip-Lock™ feature allows the panel to snap and lock positively into place. To allow for expansion and contraction:

- Do not pull on the panel as you lock it into place.
- Make sure the PermaFlex cables are straight.

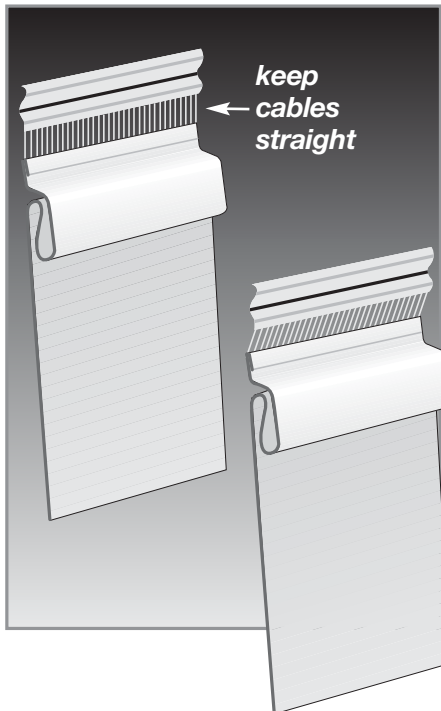

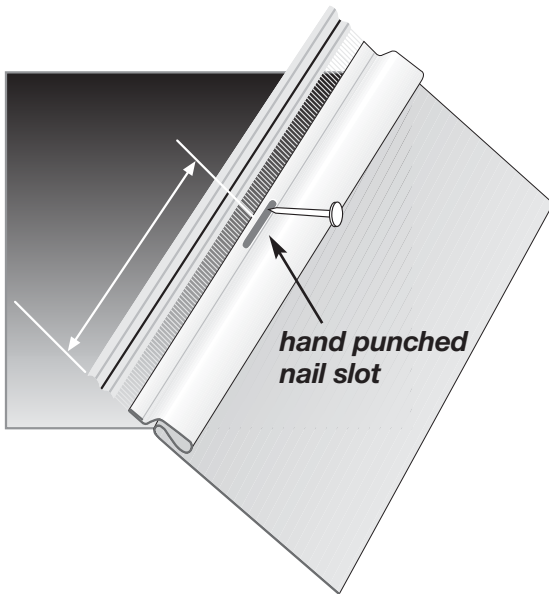

Non-Horizontal Applications

If installing these panels at 45° or less, hand punch a nail slot in the vinyl or drill a clearance hole just above the lock hoop area in the middle of the panel. You will “hang” the panel from the center pin, so hand nail the center pin as you would a typical vinyl siding panel. Then fasten the flexible hem. For Starburst installation, see pages 105-107.

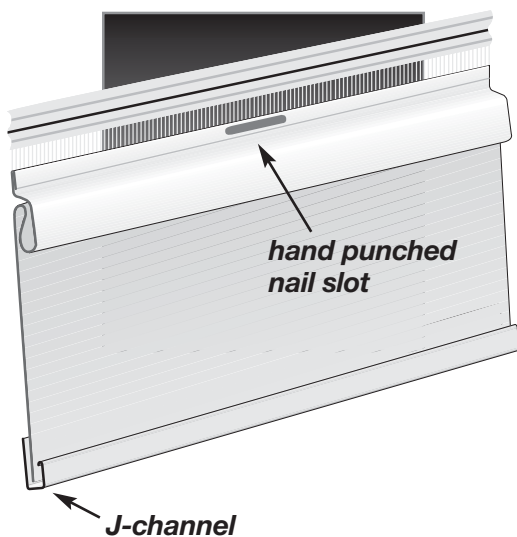

Installing Millennium without a Starter Strip

To install Millennium without a starter strip, install J-channel in place of the starter strip. Then hand punch a nail slot in the Millennium panel or drill a clearance hole just above the lock hoop area in the middle of the panel. “Hang” the panel from the center pin as you would a typical vinyl siding panel. Hand nail the center pin. If the panel is less than 16", secure it with two fasteners; otherwise, fasten the panel every 16" o.c.

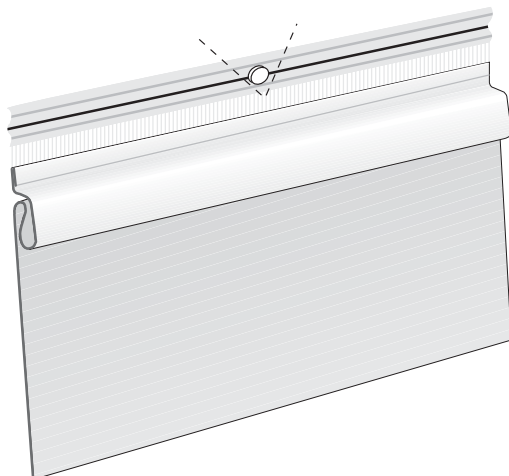

Removing Panels

To remove a panel, simply unlock the panel from the one above to expose the flexible nail hem. Use a razor knife to cut along the PermaFlex cables. Leave the nail hem on the wall or simply cut “V”s around each fastener to save the panel for another area. You can also use a flat prybar and work under the fasteners, prying each one out of the substrate.

Installing TrueComfort

TrueComfort™ insulated siding will help even out wall surfaces. However, to minimize extremes in the peaks and valleys of uneven walls, you may have to repair the underlayment. Make sure the substrate is smooth and flat. If the surface is significantly uneven, apply 1/4" foam sheathing before installing TrueComfort siding.

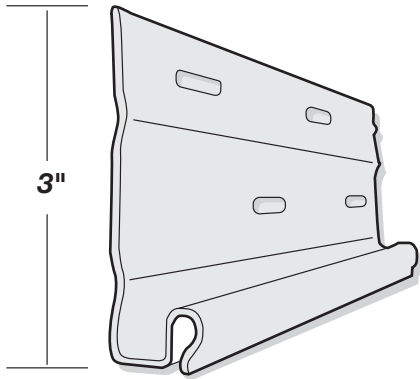

Starter strips

Insulated siding is thicker than hollow vinyl siding. To accommodate the 1-1/4" thickness, we recommend that you use the TrueComfort starter strip.

When you can't use the TrueComfort starter strip, secure the siding panel with a combination of utility trim and J-channel. To do this, you will have to remove some of the foam backing and shim accessories to accommodate the thickness of the TrueComfort panel. (See *Fitting into trim pieces*, below.)

Fastening

Use 2" corrosion-resistant nails, and penetrate the wood substrate by at least 3/4".

The nail flange on insulated siding is typically 3/4" thick. Drive the nails until there is 1/16" between the nail head and the nail flange.

Center the nail in the nail slot and drive the nail straight in. Do not drive nails at an angle.

To install TrueComfort insulated siding, follow the STUdfinder Installation System as described on the carton and on page 60 of this manual.

Fitting into trim pieces

Around windows, doors, and other openings, use 1-1/4" J-channel and outside TrueComfort cornerposts. Insert the factory- or field-cut end of the siding panel into the J-channel or cornerpost. When the outside temperature is higher than 40° F, allow a 1/4" gap between the siding and the trim. When the temperature is less than 40° F, leave a 3/8" gap.

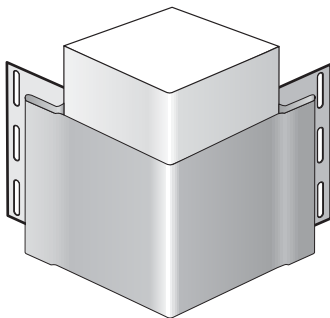
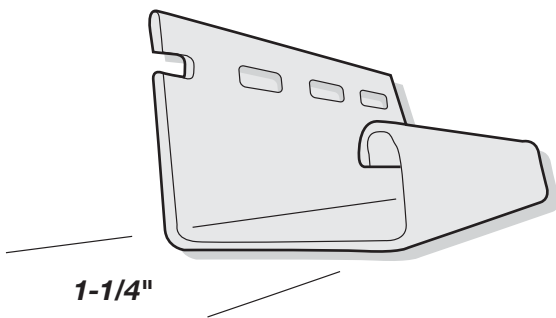

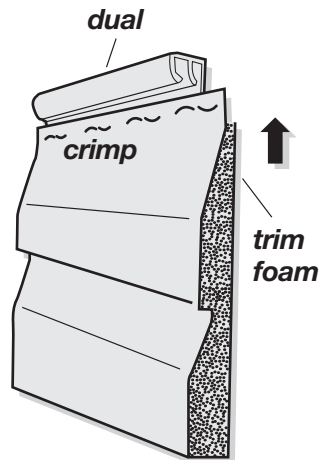

All other accessories should be fitted with foam shims and fillers. These shims will ensure that the accessories are on the same plane as the panels.

To fit panels into inside corners, remove 1-1/4" of additional foam from the ends of factory-cut panels. Remove 2" of foam from the ends of field-cut panels.

NOTE: *If you use two 1-1/4" J-channels to form the inside cornerpost (as shown on p. 31), you do not have to use shims or remove foam from the siding panels.*

Around windows and doors

Because insulated siding is thicker than hollow vinyl siding, windows, doors, and other openings may have to be built out to avoid looking recessed. Use wood shims and either aluminum trim coil or vinyl lineals to build out openings. In some cases, the foam backing in TrueComfort siding will create enough stiffness to span over or under a window without additional support.

If you are using utility trim or dual undersill trim to secure the panel, shim the trim to accommodate the thickness of the siding panel. Remove the top 1" of the foam backing so the top of the panel fits into shimmed trim. Use a snap lock punch to raise tabs every 6" to lock the panels into the trim.

When you cut a siding panel to fit around an opening, use a nail slot punch to create additional nail slots. Fasten through these additional nail slots to secure the panel. Make sure the face of the J-channel or other trim will cover the nail slots.



Under soffit

Secure the last course of siding under the soffit with utility trim, dual undersill trim, or cornice receiver with cornice molding. You will have to create tabs and nail slots as described above. You will also have to shim the trim and remove the top 1" of the foam so the top of the panel fits into the trim.

Overlapping panels

On factory-cut panels, the foam is set back 3/4" from both ends of the panel. The adhesive begins 1" back from the end of the foam. To correctly overlap the panels, slip the vinyl edge of the bottom portion of the seam between the foam and the vinyl panel. Slide the panels together until the foam ends touch.

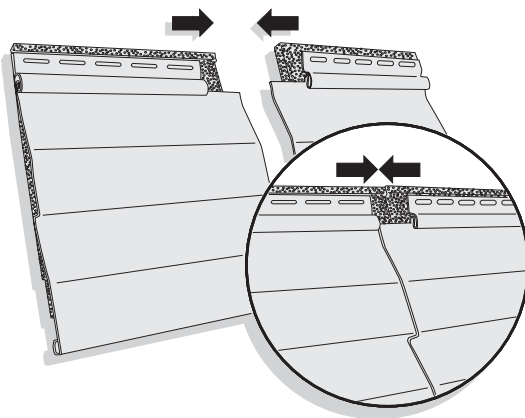

SECTION 9 – Special Situations

Trimming Curved Openings

Flexible J-channel simplifies installations around curved objects such as half and full round windows. To install around the top of an arched window, follow these simple steps:

Measure the circumference of the arch, then add 1-1/2" to allow for overlap of the bottom J-channel.

Place the channel along one side of the window, leaving a 3/4" section below the bottom edge of the window sill (shown). Position the first nail at the base of the arch. Drive the nail through the flange, tightly securing the flexible channel.

NOTE: This is an exception to the rule that says don't fasten vinyl tightly. When installed around curved objects, flexible channel must be nailed tightly.

Place additional nails every 6" along the flange. Again, nail tightly. Be sure the last nail is positioned at the base of the opposite arch.

Using a utility knife, cut through the back of the channel, at the point where it extends beyond the bottom edge of the window sill. Make a second cut perpendicular to the first at the base of the channel face. The length of the cut should equal the length of the extension (shown).

Put a 90° bend in the channel, then nail the resulting tab under the window (shown).

Repeat at opposite ends of arch.

To install the bottom J-channel, square cut the corners to overlap the flexible J-channel. Use the same technique described under "Installing window and door trim" (page 37). Use pop-rivets to secure corners (shown). Use washers on the inside of the rivets to prevent pull through.

NOTE: Remember to properly flash all windows.

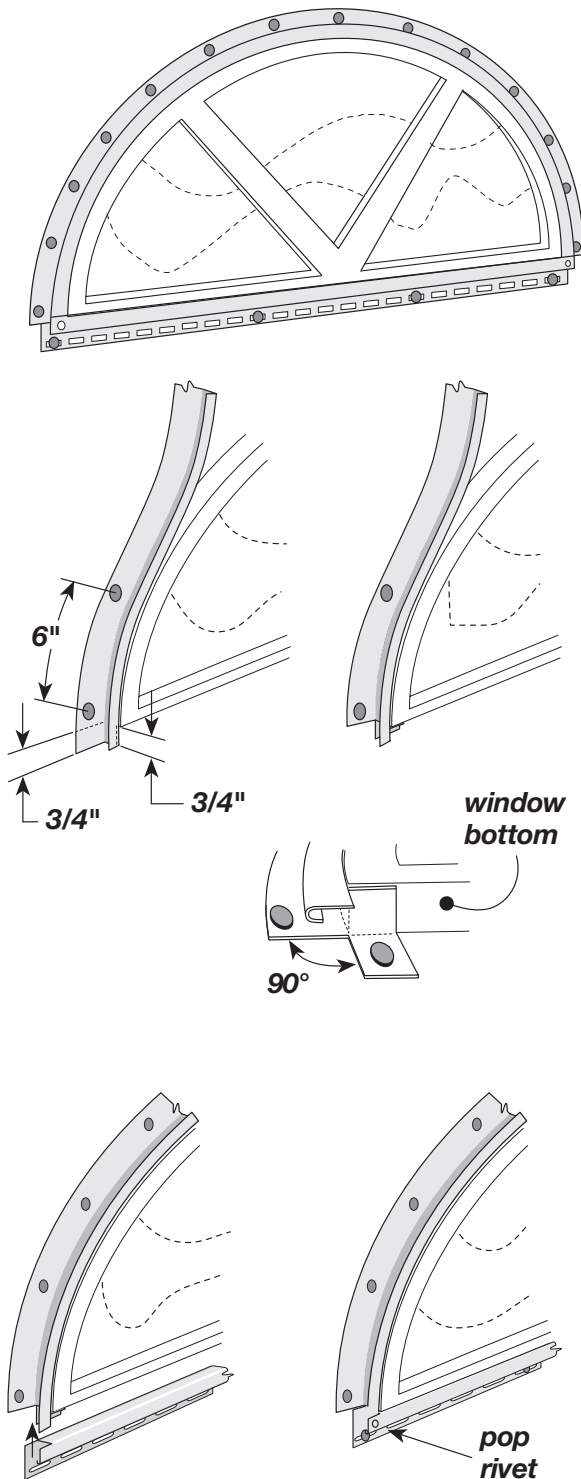

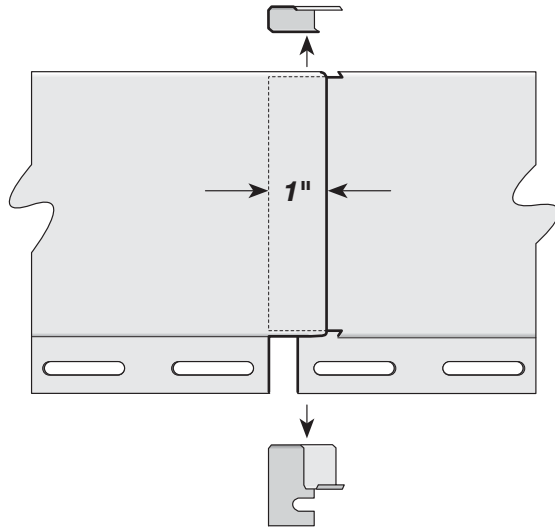

Frieze Board

A frieze-board appearance can be created using the 3-1/2" lineals in combination with new construction window starter or J-channel used as a starter.

Materials needed: 3-1/2" or 5" lineals, new construction window starter or J-channel.

Position short leg of new construction window starter against the soffit or overhang and nail in place.

Snap lineal onto locking edge of the new construction window starter between starter and soffit/overhang, and nail in place.

Trim 1-1/2" from the return leg of the overlapping lineal. Make a cut 1-1/2" at the 90° bend of the lineal face and inside (locking) edge. Trim 1-1/2" from nail flange and receiving channel. Overlap lineals 1" by fitting the notched lineal over the un-notched lineal.

An alternative to using new construction window starter is to use 1/2" J-channel as a starter. Install J-channel with back edge against soffit or overhang, then slide lineal over J-channel.

Decorative Sunbursts

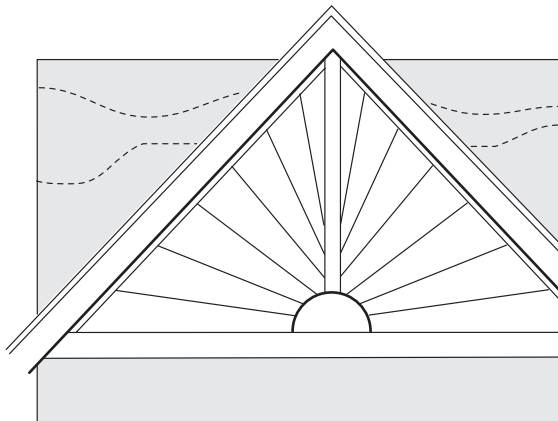

Sunbursts are not a product; they are an installation technique you can use to create an outstanding decorative finish at major accent areas such as gable ends or over garage door openings. Creating a decorative sunburst isn't difficult, but it does take patience and attention to detail. If you're ready for a professional challenge, add a sunburst to your next installation.

NOTE: *Because each sunburst installation involves unique dimensions and angles, the following instructions outline the basic technique. You must adapt these instructions to your specific installation.*

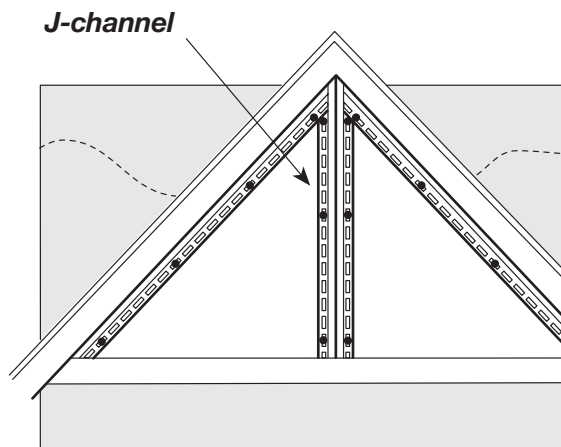

Materials needed: J-channel, starter strip, coil stock and siding. When choosing a siding panel, remember that wider panels install more quickly than narrow panels. In addition, panels with decorative profiles – for example, dutchlap – are impractical for sunburst applications. For best appearance and easiest installation, choose from single exposure or larger face double exposure panels.

Tools needed: In addition to standard installation tools, you'll need a nail hole punch and a pop rivet gun.

The following instructions assume an installation at a gable end. Refer to illustrations for each step.

Plumb J-channels back-to-back in the center of gable.

Cut the nail hem and lock off a siding panel. Put the pieces aside; you'll need them for the final step.

Measure the distance between the J-channel and the rake. Subtract an allowance for expansion. Cut the panel to this length ("proper length" in illustration). Trim the panel at the rake end to match the rake angle.

Cut the panel to the correct taper (third cut). This is a critical step, because the "flaring" of each panel allows you to create the sunburst's arch. To create the taper on a single exposure panel, start at the channel end of the panel. Mark a point 1-1/2" above the bottom butt. Then, on the opposite end, mark a point where the upper edge of the panel meets the rake. (If using double exposure panels, the mark goes under the center butt. On double exposure panels, the upper exposure is removed completely.) Now scribe a line between both points and cut with a utility knife or snips.

Pop-rivet the nail hem and lock to the trimmed panel.

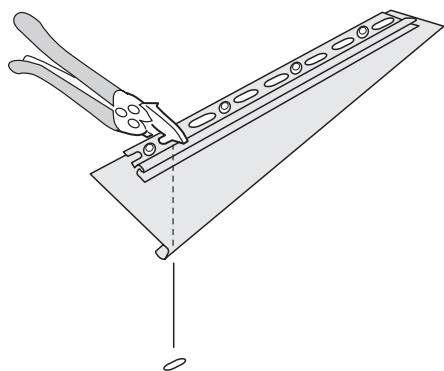
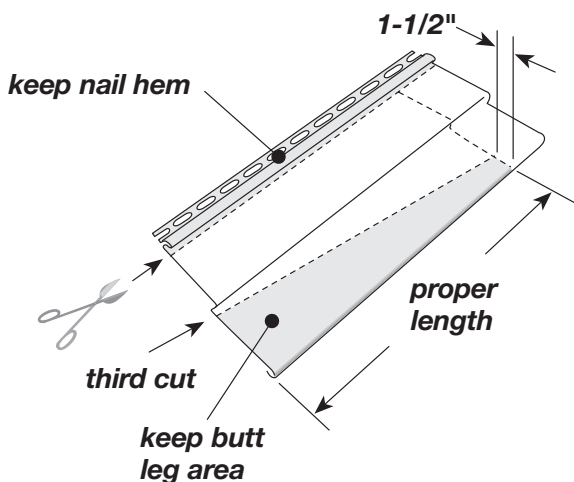

Repeat until both sides of the sunburst are completed.

NOTE: To install the final panels at the top of the sunburst, bow the panels slightly and slip them under the gable end J-channel. For added protection against high wind, you may have to face nail these panels.

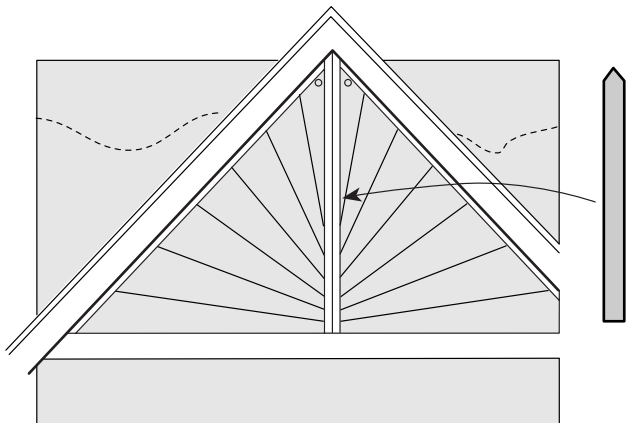
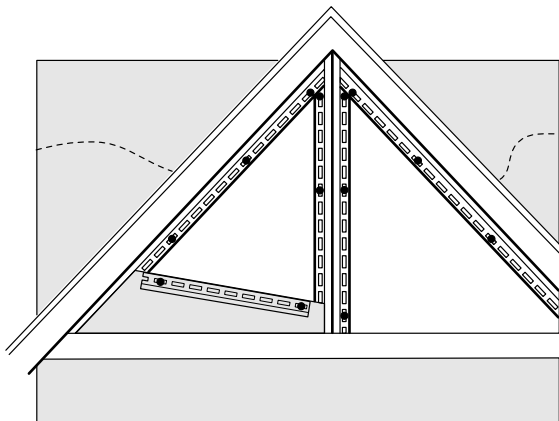

Form a sleeve from aluminum coil stock and cover the center J-channels. Secure with pop rivets.

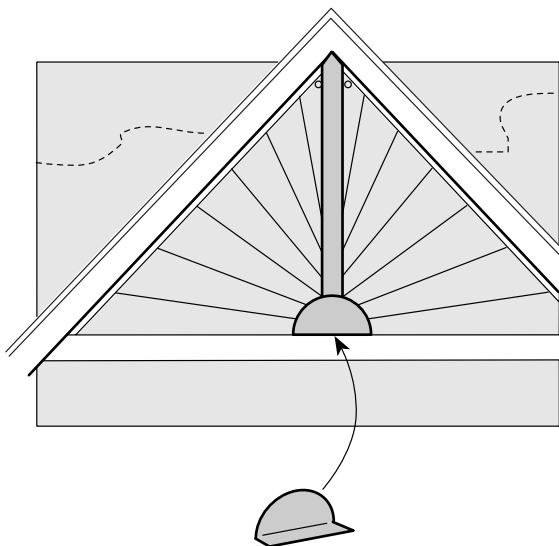

Cut an arched section from coil stock to form the "sun" portion of the sunburst. Leave a 1" strip below the arch and bend out at a right angle. Fasten the piece in place using pop rivets.

SECTION 10 – Repair

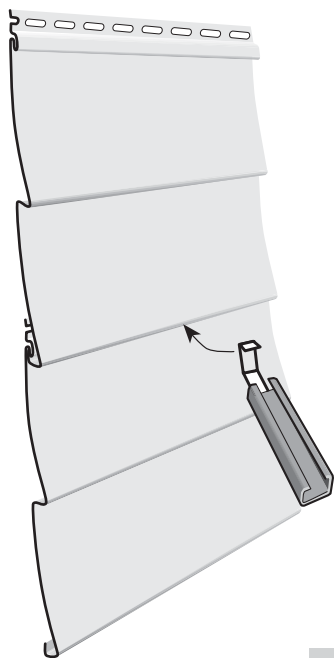

Replacing a Damaged Siding Panel

To remove a damaged panel, insert the hook end of a zip tool into the lock between the damaged panel and the panel above. Pull downward. This will allow access to the damaged panel's nail flange. Remove the nails securing the panel.

NOTE: *The nails may be allowed to stay in the wall if they are driven flush with the substrate after the damaged panel is removed. Remove damaged panel and install a new panel, then use the zip tool to lock the new panel into the panel above.*

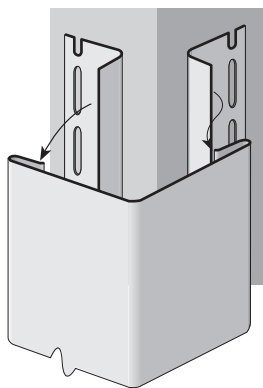

Replacing a Damaged Outside Corner Post

Remove face portion of damaged post by scoring along outside corner of receiving channel with a utility knife.

Remove the nailing flanges from the new cornerpost by scoring and bending until the flanges snap off. Be sure to score along inner corner of receiving channel.

Lap partial receiving channel of new post over partial channel on remaining nail flange. Pop rivet the two receiving channel legs together as needed.

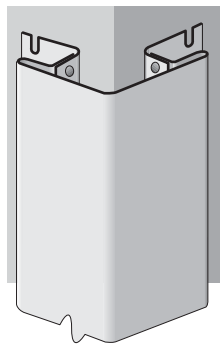
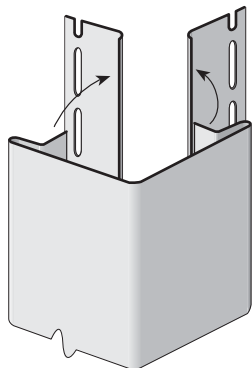

Repairing Buckled Siding at the Joist

Vinyl siding sometimes becomes buckled between the first and second floors of a newly built siding installation due to settling and shrinkage of wet lumber and some framing practices. Using “engineered” lumber for the joist greatly reduces the chances of shrinkage and settling and can help prevent buckling of siding. If, however, you do have a building with this situation, here is a way to correct the problem using aluminum starter strip.

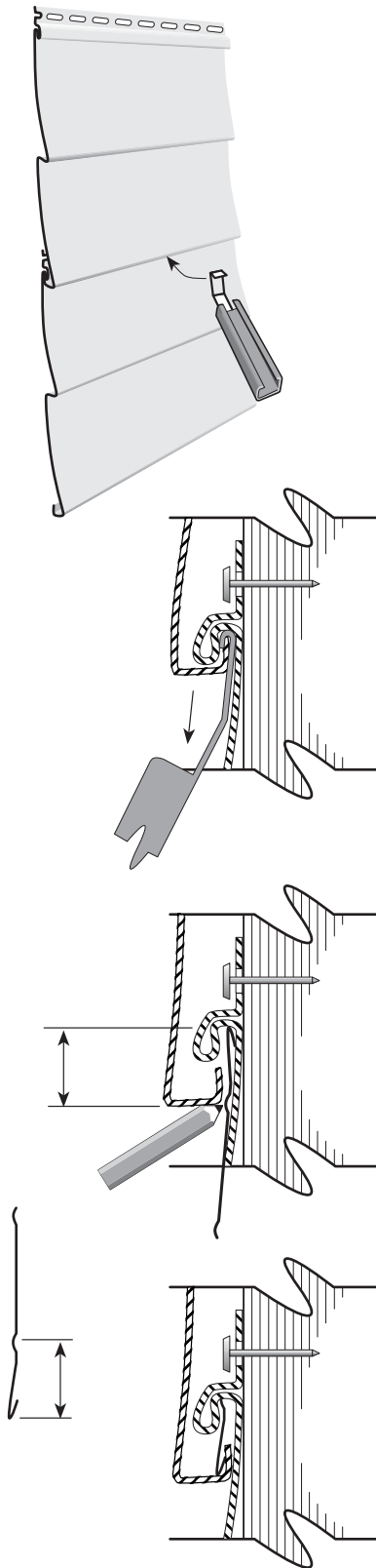

With a zip-lock tool unlock the buckled panel from the panel below by inserting the hooked end of the tool behind the return leg of the buckled panel until the hook catches. Pull down and “unzip” the panel.

Insert an inverted scrap piece of starter strip into the exposed receiving lock of the lower panel.

With the scrap piece inserted into the lock, lay the upper panel over the starter strip. The starter strip should be visible behind the upper panel. Mark a line on the scrap piece where the return leg of the upper panel meets the scrap piece.

Trim the starter on this line, saving the portion with the locking edge.

NOTE: Cut the starter strip in shorter lengths to ease handling and relocking.

Insert the trimmed edge into the lock of the lower panel. Begin at one end and, using a zip-lock tool, pull the return leg of the upper panel down to engage the upper panel with the aluminum starter strip.

SECTION 11 – Miscellaneous

Cleaning Vinyl Siding

Vinyl siding resists most common household stains, but it will become dirty like any product exposed to atmospheric conditions. In areas not exposed to direct sun and rain, periodic washing with a soft bristle brush and clean water from a garden hose may be necessary to remove surface dirt. Chalk may also accumulate on the surface. This is a normal condition for pigmented materials exposed to the elements.

For best appearance, clean vinyl siding at least once a year.

To remove soil, grime and chalk from your siding, use a garden hose, a soft bristle brush and a bucket of soapy water. (You can also use the solution described below in the section dealing with mildew.) To minimize streaking, wash the house from the bottom up.

Thoroughly rinse the siding with clean water from a garden hose. Avoid prolonged or high pressure rinsing of open ventilated areas. Keep cleaning solution off surrounding fixtures and surfaces not scheduled for washing.

Stubborn stains

If you can't remove especially stubborn stains using normal household detergents, request a cleaner from your siding contractor or your local building materials retailer. Always test any cleaner on an inconspicuous area before full use.

Mildew

Mildew may be a problem in some areas, especially warmer climates with consistently high humidity. Mildew appears as black spots on surface dirt and is usually detected in areas not subjected to rainfall, such as under eaves and porch enclosures. To remove mildew, prepare a solution as follows:

1/2 cup detergent (Tide, for example)

2/3 cup trisodium phosphate (Soilax, for example)

1 quart 5% sodium hypochlorite (Chlorox, for example)

3 quarts water

CAUTION: Greater concentration may cause damage to the siding and soffit.

If the above solution does not readily remove mildew spots, ask your siding contractor or your local building materials retailer for a mildew cleaner.

Siding over Asbestos

Vinyl siding retrofit over asbestos

This is a recommendation from the Vinyl Siding Institute after discussions with Federal EPA officials. Because local regulations supersede federal regulations, local EPA officials should be contacted in the area where the work is being done.

The most desirable practice is not to disturb the existing siding on the home. Apply sheathing over the existing asbestos siding and then apply vinyl siding over the top of the sheathing. The sheathing will serve to flatten the wall and also retain any breakage of the cement asbestos siding. Nails should be long enough to penetrate the sheathing, existing asbestos siding and into the wall studs.

If there is a need to level or flatten a wall, apply furring strips over sheathing.

In the case where the homeowner wants the existing cement asbestos siding removed completely, removal should be done by a professionally trained asbestos removal crew.

Please note that some jurisdictions require all asbestos removal to be performed by a trained asbestos removal crew.

Historic Restoration

Vinyl Siding Institute recommended guidelines

If a building is in an historic area or has been designated an historic building, be certain that approval for the use of vinyl siding has been obtained from the local historic society. This applies to building additions as well.

Before proceeding to re-side an historic building, the building should be examined for moisture, insect infestation, structural defects and other problems which may be present. These problems should be addressed and the building pronounced "healthy" before re-siding with any material.

Do not damage or remove the original siding. If at all possible, do not alter the original structure so that the application of vinyl siding is reversible (i.e. the original would remain intact and some time in the future, if desired, the vinyl siding could be removed). Exception: "In cases where a non-historic artificial siding has been applied to a building, the removal of such a siding before the application of vinyl siding would, in most cases, be acceptable." (Preservation Briefs, Number 8 - U.S. Dept. of the Interior - 1984)

Exercise every care to retain architectural details wherever possible. Do not remove, cover or add details until you have the building owner's written approval. Determine that the owner has consulted the local historic society regarding the foregoing.

Use siding which closely approximates the appearance of the original siding in color, size and style.

For More Information

We believe these instructions will enable you to successfully complete a siding, soffit or porch ceiling installation. But we also realize that no set of instructions can answer every question or problem that might come up during a project. So if you are in doubt about how to complete a specific procedure, we suggest you try two avenues of help:

First, call or visit your building materials supplier. You should be able to find someone with the knowhow and experience to answer your question or solve your problem.

Second, if you need additional help, call us at 1-888-838-8100. Our Sales Support Group representatives are always ready to help you.



Toll-free: 888-838-8100

WT111/0105 © 2005 Wolverine